

# Symphony™ Audio DSP56724/DSP56725

## Target Applications

- A/V receivers
- Car audio/amplifiers
- Digital TVs
- DVD receivers
- Effects boxes
- Guitar amplifiers
- Home Theater in a Box (HTiB)
- Musical instruments
- Professional audio recording systems
- Speakers

## Overview

Freescale's venerable Symphony™ audio DSP family has driven innovation in the world of high-fidelity for nearly twenty years. All through the audio creation chain, Symphony audio DSPs can be found, shaping and perfecting what you hear in your home and automobile, in the theater, concert hall and even professional sound studios. With the rapid growth of

multi-channel and high-definition audio systems, Freescale is expanding our multicore portfolio with the Symphony DSP56724 and DSP56725 DSPs. Ideal for cost-sensitive applications, these devices offer an impressive performance of 250 MHz per core for a total of 500 million instructions per second (MIPS) processing power. OEMs seeking to expand their product line across various market tiers may also find these devices appealing. The Symphony multicore DSP56724/DSP56725 devices are pin and peripheral compatible with the Symphony multicore DSP56720 and DSP56721 DSPs to enable ease of migration. With this family of devices, customers have the flexibility to pick the device with the right performance and price to match their design requirements.

The Symphony audio DSP56724 and DSP56725 excel at audio processing for automotive and consumer audio applications

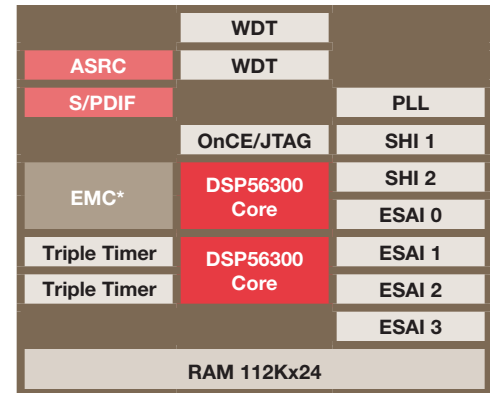

**DSP56724/725 Block Diagram**

\* EMC available on DSP56724 only.

requiring high MIPS. In addition, these DSPs are optimal for the professional audio market requiring audio recording, signal processing and digital audio synthesis. As systems become more complex and need to incorporate more features, the need for more MIPS becomes extremely important.

Features	Benefits
<b>Dual High-Performance 24-bit DSP56300 Cores</b>	
<ul style="list-style-type: none"> <li>• 250 MHz per core for a total of 500 MIPS performance at consumer temperature range</li> <li>• 200 MHz per core for a total of 400 MIPS performance at automotive temperature range</li> <li>• Dual data arithmetic logic units (ALU) with a 24 x 24-bit multiplier accumulator and a 56-bit barrel shifter</li> <li>• Eight-channel DMA controller per core</li> <li>• Stop and wait low-power standby modes</li> <li>• Double precision mode to provide 48-bit accuracy when needed</li> </ul>	<ul style="list-style-type: none"> <li>○ Designed to provide the high performance necessary for many audio applications</li> <li>○ Dual-core architecture allows optimized use of memory and MIPS</li> </ul>
<b>On-Chip Debug Interface</b>	
<ul style="list-style-type: none"> <li>• Internal address tracing support and on-chip emulation (OnCE) module per core</li> <li>• JTAG port</li> </ul>	<ul style="list-style-type: none"> <li>○ Allows for real-time software development and software download to on-chip or on-board RAM</li> <li>○ Allows for software running and debug with full-speed operation and breakpoint capability, and the ability to modify all user-accessible registers, memory and peripherals</li> </ul>
<b>On-Chip Memory Configuration</b>	
<ul style="list-style-type: none"> <li>• 112K x 24-bit words RAM</li> <li>• Partitioned into program memory space, X and Y data memory space</li> <li>• Shared memory between the two cores</li> </ul>	<ul style="list-style-type: none"> <li>○ Flexibility</li> <li>○ Allows two address ALUs and the ability to feed two operands simultaneously to the data ALU</li> <li>○ Provides flexibility to the user by allowing custom allocation of memory</li> </ul>
<b>External Memory Controller (EMC)</b>	
<ul style="list-style-type: none"> <li>• Supports external memories: SDRAM, SRAM, flash and EEPROM</li> <li>• External memory is accessible via either core and any memory space</li> <li>• Available on the DSP56724 only</li> </ul>	<ul style="list-style-type: none"> <li>○ Provides for memory expansion to either cost-effective SDRAM or fast SRAM</li> <li>○ Provides flexibility in system design by providing memory expansion for one or both cores</li> </ul>
<b>Asynchronous Sample Rate Converter (ASRC)</b>	
<ul style="list-style-type: none"> <li>• Ten channels</li> <li>• Input and output sample rate 32 kHz to 192 kHz</li> <li>• Three input and output clock ratio conversions</li> <li>• Shared by the two cores</li> </ul>	<ul style="list-style-type: none"> <li>○ Allows multiple audio data rates in a system</li> <li>○ Synchronizes up to three asynchronous audio streams</li> </ul>

## S/PDIF Transceiver Module

- S/PDIF receiver module with four mux'd inputs
  - S/PDIF transmitter module with two outputs
  - Supports IEC958, IECG-1937 format
- Reduces system costs by integrating SPDIF transceiver on-chip

## Four Enhanced Serial Audio Interfaces (ESAI)

- Two dedicated Tx and four selectable Tx/Rx signals
  - TDM capable with up to 32 words per frame
  - Supports many programmable protocols such as I2S, Sony, AC97 and network
  - Two ESAI ports per core
- Glueless connection to industry standard CODECS (I<sup>2</sup>S, left justified, right justified and AC97)
  - Full-duplex serial port for serial communications with DSPs, MPUs and MCUs

## Dual Serial Host Interfaces (SHI)

- Serial peripheral interface (SPI) protocol
  - Inter-IC (I<sup>2</sup>C) protocol
  - Support for 8-, 16- and 24-bit width data transfers
- High-speed synchronous communication between multiple DSPs or between DSP and MCU or between DSP and serial peripherals
  - Designed to provide a simple, efficient method of data exchange between devices

## Dual Triple Timer Module

- Timer, measurement, PWM, watchdog modes available
  - Three timers per module, one module per core
- Flexible, programmable timer system

## Dual Hardware Watchdog Timers (WDT)

- Based on a 16-bit free-running down counter
  - One WDT per core
- Allows recovery from runaway code

## Symphony™ Audio DSP56724/DSP56725

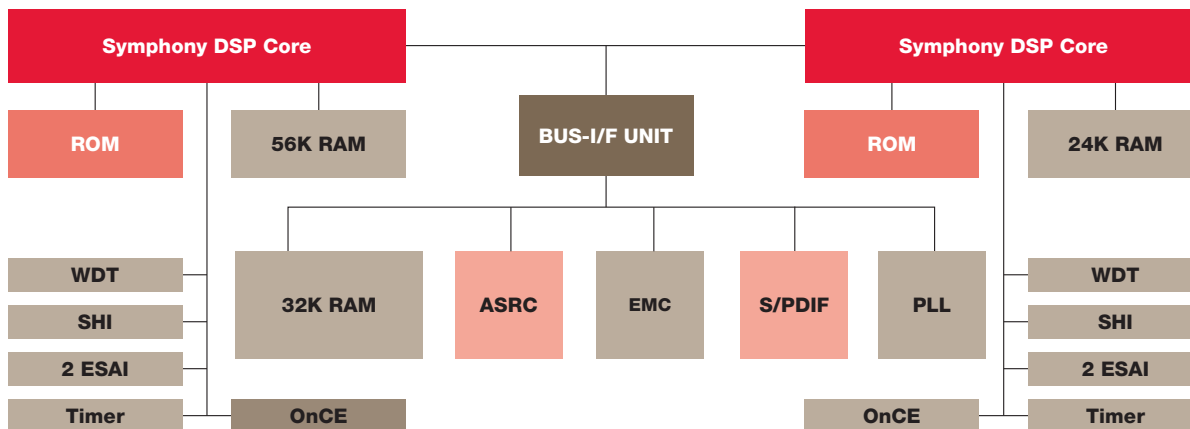

### Development Tools

**DSPAUDIOEVMMB1E:** Generic motherboard that is used (along with a specific daughtercard) to demonstrate the abilities of the DSP563xx and DSP567xx families and provides a hardware tool to allow development of applications that use these devices. \$750\*

**DSPB724DB1E:** Daughterboard for DSPB56724 used with the motherboard. \$399\*

**DSPB725DB2E:** Daughterboard for DSPB56725 used with the motherboard. \$399\*

**Symphony Studio:** Robust tool suite for DSP56300/DSP56700 family of DSPs that include an assembler, linker, simulator, debugger and several utilities within an Eclipse-based integrated development environment (IDE). Free\*\*

\*Prices listed are Manufacturer's Suggested Resale Price (MSRP)

\*\*Subject to license agreement and registration

**Learn More:** For current information about Freescale products and documentation, please visit [www.freescale.com](http://www.freescale.com).

For more information about Symphony audio DSPs, please visit [www.freescale.com/symphony](http://www.freescale.com/symphony).