

# Buffalo III/IISE DAC Integration Guide Revision 2.0.0

---

By Leon van Bommel

# Table of Contents

About this manual .....	4
Overview .....	5
Designing your DAC.....	7
Input options for the Buffalo III DAC module.....	10
Connecting sources directly to the Buffalo III DAC board.....	11
Using the built-in Mux of the Buffalo III: the S/PDIF-4 Input Board.....	13
S/PDIF and PCM/DSD for the Buffalo III: Sidecar .....	16
S/PDIF for the Buffalo III: Single S/PDIF Level Converter .....	18
Preparing the Buffalo III board .....	19
Buffalo III DIP switch settings.....	26
Buffalo III specification .....	30
Lay-out of Buffalo III module – Top side .....	31
Lay-out of Buffalo III module – Bottom side .....	33
Pin lay-out of the Buffalo III digital input connector.....	35
Input options for the Buffalo IIISE DAC module.....	37
Connecting sources directly to the Buffalo IIISE DAC board.....	38
Preparing the Buffalo IIISE board .....	39
Buffalo IIISE DIP switch settings.....	43
Buffalo IIISE specification .....	46
Lay-out of Buffalo IIISE module .....	47
Pin lay-out of the Buffalo IIISE digital input connector .....	49
Adding COAX input.....	51
Adding AES/EBU input.....	52
Adding USB input.....	53
Adding the Trident regulator.....	54
Adding volume control.....	55
Adding the Teleporter.....	56
Adding the S/PDIF 4:1 MUX/Receiver Module .....	58
The input selection switch: the 2-bit Selector board .....	61
Adding the Metronome.....	63
Multiple I2S/DSD connections: OTTO-II .....	65
Adding optical input: the TOSLINK Optical Input Module .....	66
Advanced features .....	67
Powering it all.....	68
Appendix: Pin lay-out of the external I/O connector .....	72
Appendix: Bill of materials for stereo mode DAC.....	73
Appendix: Bill of materials for dual mono mode DAC.....	74

Appendix: Bill of materials for multi channel DAC .....	75
Appendix: Extended bill of materials.....	76
Appendix: References.....	79

## About this manual

This manual provides a supplement for the official, separate module manuals. It combines information from the original Buffalo II and III manuals, the DIYAudio forum (<http://www.diyaudio.com/forums/twisted-pear/>) and the Twisted Pear Audio forum. It handles the most popular Buffalo III-series configurations and is mainly intended for people new to the Twisted Pear Audio modules.

This is by no means a replacement for the official manuals: the modules features and specifications are subject to constant improvement. See <http://www.twistedpearaudio.com/docs/docs.aspx> for the latest versions of the official and community manuals.

### Conventions

In the text the reference (<part>, <number>) will be used, where <part> is the marking on the board, and <number> means the number of the part as found in the lay-out. In general, the reference will also act as a hyperlink which leads back to either the top or bottom lay-out, depending on location of the part. Sometimes reference SW<number>:<switch> will be used, where <number> refers to the DIP switch block (SW1 or SW2), while <switch> refers to the switch number within the block.

### Naming of the Buffalo board

In the text the name Buffalo III-series or Buffalo III/IIISE board means either the Buffalo III or the Buffalo IIISE board, indicating things apply to or work with both boards. If the text only mentions the Buffalo III board or the Buffalo IIISE board, that part only applies to that particular version of the DAC board.

# Overview

The Buffalo III-series are 32-bit 1 to 8 channel audio reference DAC modules designed for uncompromising audio quality. Based on the ESS Technology ES9018 Sabre Reference chip, the Buffalo III-series accept S/PDIF, PCM, and DSD digital audio signals at sample rates up to 32-bit / 400Khz.

## Modes

The ES9018 chip is an 8 channel DAC, capable of working in several different modes. The Buffalo III can be used in multiple ways: mono, stereo and multi channel modes are all available. The Buffalo IIISE can only be used in mono or stereo modes.

Module	Mono	Stereo	Multi-channel
Buffalo III	√	√	√
Buffalo IIISE	√	√	-

In dual mono mode two Buffalo III/IIISE boards are used. One board is used for the left output and one for the right output. In that mode all 8 balanced DACs of the ES9018 are used for each output channel achieving the best possible dynamic range.

In stereo mode, one board is used to drive both outputs (L+R channel). In that mode, four of the balanced DACs inside the ES9018 are combined to one output channel. This improves dynamic range when compared to the 7.1 mode where only one DAC is used per output channel.

With the Buffalo III board, one can also combine multiple channels, or simply use each channel individually. This allows one to create for instance a 4-channel or 8-channel setup.

## In the package

The Buffalo III/IIISE is shipped with everything you need to integrate it into your project:

- Buffalo III-series DAC board
- AVCC module
- LEDs for Lock and Mute
- Connector block for power, input and external I/O
- Stacking connectors for the AVCC module
- Stacking connectors for the Twisted Pear Audio I/V stages
- Volume pot for on-board volume control

And for the Buffalo III:

- Jumpers (0Ω SMD resistors) (these are not required for the Buffalo IIISE board)

Note: contents of the package are subject to change without further notice.

## AVCC Module

The AVCC module for the analog supply pins of the DAC should be connected so that the header pins connect to the same pin on the DAC board. You might note that we use an AVCC voltage that is slightly higher than 3.3VDC. This helps us achieve slightly better dynamic range. The module is supplied with a CCS fed shunt regulator especially designed for the analog section (AVCC) of the ES9018.

This manual assumes you are using that regulator module as it has been designed specifically for the Buffalo III/IIISE.

## Power requirements

The Buffalo III/IIISE board is designed to be used with the Twisted Pear Audio Trident modules for local power regulation. These shunt regulators are designed specifically for the Buffalo II and III series of boards. The Buffalo III-series is modular however: if one wishes, other power supplies can be used to power each of the sections of the Buffalo III/IIISE board. With the exception of the on-board linear regulator for the on-board controller each voltage regulator can be replaced easily.

The standard Buffalo III/IIISE board requires an input voltage of 5.25V and it draws approximately 440mA when one is using the recommended set of Trident shunt regulators. We recommend using either a Placid HD tuned for shunting about 50mA (approx. 490mA CCS current) or half of a LCDPS. See the Placid HD manual for more detail.

## Analog characteristics

The Buffalo III-series boards do not include an output stage but are designed to mate with a Twisted Pear Audio current-to-voltage stage (I/V stage) like the IVY III or Legato 3.1. For this reason, the mounting holes have the exact same lay-out as the Buffalo II version of the DAC module.

It is not recommended to use the Buffalo III/IIISE output directly, but it is possible. The output can be used as a voltage source into a high impedance but THD+N will suffer. THD+N as a voltage source is about -108db whereas when used with a very low input impedance current to voltage stage such as the IVY III it can achieve -120db THD+N in mono mode.

## Clock

The Buffalo III/IIISE DAC board uses a custom on-board ultra low jitter, low phase noise 100Mhz clock from Crystek. The clock module lowers jitter significantly when compared to normal clocks. The clock is placed on the board near the DAC chip to keep phase noise at low levels. It is recommended not to use an external clock to feed the DAC chip as the increased distance to the chip and resulting phase noise would likely offset any benefit from the external clock (even if you can find a better module).

Disabling the on-board clock on the Buffalo III is possible, but not recommended or supported.

For people who want to experiment with synchronous clocks: the Buffalo IIISE has a special uFL connector ([EXT\\_MCK, 6](#)) plus a normal 0.1" header ([E\\_CK, 8](#)) for connecting a master clock. By not powering the clock module an external master clock can be connected to the uFL connector or the header on the Buffalo IIISE. Alternatively, these positions can also be used to connect the clock module as a base for external usage.

# Designing your DAC

## Buffalo III or IIISE?

The Buffalo III is the most flexible board, but it requires more work and in most cases more modules to build a complete solution. For normal usage this will lead to a higher cost, so in most cases the IIISE board will be the way to go.

The Buffalo IIISE board however is limited to stereo or dual mono usage, if you plan to use the board for a multi-channel DAC you'll need to use multiple boards. This means a vast increase in cost when compared to a single Buffalo III board.

## Volume or no volume control?

There are virtually no drawbacks to using the volume control on the Buffalo III/IIISE. The Buffalo III-series features this volume control on-board, so it's basically now a free option. When the volume is set to 100%, it sets the registers of the DAC chip to 0 just like they would be when there is no volume control present. After setting the registers, the I2C communication stops so there's no interference from the I2C signal to the D/A conversion stage. More information can be found in the section [Adding volume control](#).

## When to use the IVY III or Legato 3.1

The choice between the IVY III and Legato 3.1 I/V stages is mainly one of preference. In the ideal case, you should choose the I/V stage you prefer. But there are some design issues one has to think about when choosing the right I/V stage for your DAC. And many of these have to do with the background of these 2 I/V stages.

The IVY III is a fully-differential amplifier design, uses a fairly low amount of parts and uses a relatively low amount of power. The Legato 3.1 however is largely a discrete class A design and only uses an opamp for the balanced to single-ended conversion. It uses much more components and consumes more power, so it needs a greater amount of cooling. It also features a much lower amount of power available at it's balanced outputs.

Difference	IVY III	Legato 3.1 with buffer
<b>Design</b>	Opamp based	Largely discrete, with buffer on SE outputs
<b>Efficiency</b>	High	Low
<b>Output impedance</b>	Extremely low	Low
<b>Stock output voltage</b>	2V	1.5V
<b>Power required</b>	2x15V, 90 ~ 150mA	2x15V, 350mA
<b>Balanced outputs</b>	Medium current	Low current
<b>Single ended outputs</b>	Medium current	High current (250mA when using the buffer)

Given the differences, for stereo usage the IVY III is ideal for use in a small chassis or for multi-channel solutions and also if you want to connect your balanced headphones directly to the DAC. The Legato 3.1 with buffer is ideal for driving single ended headphones.

This changes a little when going dual mono. In this case, the Legato uses the buffer to drive the left and right SE outputs, which are even more powerful than those found on the IVY III. So when one wants to drive balanced headphones from a dual mono setup, the Legato 3.1 with buffer is an ideal choice.

For a those that want to build a dual mono setup and still be able to connect singled ended headphones, the Ventus EZ is the best addition: not only does this board convert balanced to single ended, it also has a Diamond buffer which like the Legato's buffer is capable of delivering up to 250mA of current.

When using the Legato, remember to trim it to remove any differential DC (measured between the balanced outputs). And if your amplifier can't handle common mode DC (measured from either output to GND) or if you are not sure: add coupling caps to the outputs.

In general, the IVY III measures better and is an easier module to use for most users. IVY III is the preferred output stage for the majority of situations.

### **Lay-out considerations**

Designing a good lay-out for your DAC will prove beneficial in the long run. Planning your layout not only simplifies your cabling, but in some cases it will also improve the performance of your DAC. There are some design rules you should follow:

- Keep AC lines away from other cables. Never let them run parallel to other cables over a significant length. That would introduce a 50 or 60Hz interference into your system.
- Keep DC cables short. This improves the stability of the PSU section.
- Keep signal lines short.
- Keep I2S cables as short as possible, for high resolution sound one should keep them at least below 4" (10cm) and of equal length.

### **Tips for a clean and safe setup**

- Twist all primary and secondary transformer leads.
- Twist all leads coming from the bridge rectifiers/PSU PCB/buffer caps.
- Clean up the wiring, twist all wires that carry AC current, route them clear of DC/signal wires.
- Clean the boards after soldering with Isopropyl alcohol.
- When using a metal chassis, work with double isolation on all wires carrying high voltage AC current or keep at least 10mm distance between the wire and the chassis.
- Use a fuse. This is easy to do when using a chassis power connector with integrated fuse holder.

# The Buffalo III Board

*Flexibility without compromise*

The following chapters handle the instructions and modules for the Buffalo III DAC board. Go to [The Buffalo IIISE Board](#) when you are building a Buffalo IIISE-based DAC.

# Input options for the Buffalo III DAC module

The Buffalo III DAC board exposes all 8 digital inputs of the ES9018 chip. All of these inputs are available on the 20-pin input connector ([DIN, 1](#)) on the edge of the board. In contrast to the Buffalo II board, the Buffalo III no longer has an on-board comparator. So the Buffalo III only supports TTL level S/PDIF next to the usual I2S and DSD signals. Unless your source explicitly states it outputs TTL level S/PDIF you should assume it's output is consumer level S/PDIF. For consumer level S/PDIF a comparator or other type of conversion is needed.

Although TTL S/PDIF, DSD and I2S signals are supported and all digital inputs are available, only one type of signal can be used at a time. So for on-the-fly switching between fi. I2S and S/PDIF one still needs an off-board solution like the Sidecar.

When using high resolution sources I2S input is preferred, as unlike the S/PDIF input it is not limited to 24-bit / 192KHz. Keep I2S wires as short as possible, and when using dual mono mode make sure the I2S wires are of equal length to eliminate timing issues. In short:

Input	Channels	Notes
<b>S/PDIF</b>	2	Limited to 24-bit / 192KHz, convert it to TTL level
<b>PCM (I2S)</b>	2, 4, 6 or 8	Keep wires short or use the <a href="#">Teleporter</a> module
<b>DSD</b>	1 to 8	

## More than 4 inputs

As stated, the Buffalo III supports 8 inputs. For people who require input selection for more than the 4 S/PDIF +1 stereo DSD/PCM (I2S) inputs offered by the S/PDIF-4 Input Board and Sidecar combo, there is also the possibility to use a microcontroller like an Arduino or AC2, connect it to the Buffalo III module using I2C and select the input by software. This allows access to all 8 S/PDIF inputs and switching between them. Please beware that when you want to connect both DSD or PCM (I2S) and S/PDIF signals, you also need an off-board switch module (fi. OTTO-II) to disable one of the signal types.

## Specific input modules

These are the input modules specifically built for Buffalo III:

Module	Inputs	Output
<a href="#">S/PDIF-4 Input Board</a>	4 consumer level S/PDIF inputs, including AES/EBU	20-pin connector for Buffalo III/Sidecar
<a href="#">Sidecar</a>	Terminal block for I2S/DSD, 20-pin connector for S/PDIF-4 Input Board	20-pin connector for Buffalo III
<a href="#">Single S/PDIF Level Converter</a>	1 consumer level S/PDIF input, including AES/EBU	2-pin connector

# Connecting sources directly to the Buffalo III DAC board

Although many will prefer to use input modules like the S/PDIF-4 Input Board and Sidecar, it is possible to connect digital sources directly to the Buffalo III DAC board.

## TTL level S/PDIF

For TTL level S/PDIF the following connections are possible, stereo only:

Connection	DIN ( <a href="#">DIN, 1</a> )
<b>S/PDIF input 1</b>	D1, GND
<b>S/PDIF input 2</b>	D2, GND
<b>S/PDIF input 3</b>	D3, GND
<b>S/PDIF input 4</b>	D4, GND
<b>S/PDIF input 5</b>	D5, GND
<b>S/PDIF input 6</b>	D6, GND
<b>S/PDIF input 7</b>	D7, GND
<b>S/PDIF input 8</b>	D8, GND

If you want to use all inputs, remove the following jumpers if they are present:

- JPCM1 ([JPCM1, 3](#))
- JPCM2 ([JPCM2, 1](#))
- JPCM3 ([JPCM3, 2](#))
- JDSD1 ([JDSD1, 5](#))
- JDSD2 ([JDSD2, 4](#))

Last step: set the DIP switch [S/PDIF auto-detect](#) to Use (OFF).

## TTL level PCM

The Buffalo III DAC board also supports TTL level PCM (I2S by default), which can be multi-channel:

Source connection	DIN ( <a href="#">DIN, 1</a> )	Channel
<b>GND</b>	GND	
<b>Bit clock</b>	DCK	
<b>Word clock(LRCK)</b>	D1	
<b>Data</b>	D2	1 and 2
	D3	3 and 4
	D4	5 and 6
	D5	7 and 8

### Stereo PCM without Sidecar

When using stereo PCM without Sidecar, D2-D5 should be joined via the PCM jumpers. Place the following jumpers:

- JPCM1 ([JPCM1, 3](#))
- JPCM2 ([JPCM2, 1](#))
- JPCM3 ([JPCM3, 2](#))

And remove jumpers if present from:

- JDSD1 ([JDSD1, 5](#))
- JDSD2 ([JDSD2, 4](#))

Last step: set the DIP switch [S/PDIF auto-detect](#) to Bypass (ON).

### Multichannel PCM

If you want to use all channels, remove the following jumpers if they are present:

- JPCM1 ([JPCM1, 3](#))
- JPCM2 ([JPCM2, 1](#))
- JPCM3 ([JPCM3, 2](#))
- JDSD1 ([JDSD1, 5](#))
- JDSD2 ([JDSD2, 4](#))

Set the DIP switch [S/PDIF auto-detect](#) to Bypass (ON).

Last step: set the DIP switch [Input remapping](#) to OFF.

### TTL level DSD

And the Buffalo III DAC board supports TTL level DSD, which also can be multi-channel:

Source connection	DIN ( <a href="#">DIN, 1</a> )
<b>GND</b>	GND
<b>Bit clock</b>	DCK
<b>Data 1</b>	D1
<b>Data 2</b>	D2
<b>Data 3</b>	D3
<b>Data 4</b>	D4
<b>Data 5</b>	D5
<b>Data 6</b>	D6
<b>Data 7</b>	D7
<b>Data 8</b>	D8

### Stereo DSD without Sidecar

When using stereo DSD without Sidecar one should use the DSD jumpers. Place the following jumpers:

- JDSD1 ([JDSD1, 5](#))
- JDSD2 ([JDSD2, 4](#))

And remove jumpers if present from:

- JPCM1 ([JPCM1, 3](#))
- JPCM2 ([JPCM2, 1](#))
- JPCM3 ([JPCM3, 2](#))

Set the DIP switch [S/PDIF auto-detect](#) to Bypass (ON).

Last step: set the DIP switch [Input remapping](#) to ON.

### Multichannel DSD

If you want to use all channels, remove the following jumpers if they are present:

- JPCM1 ([JPCM1, 3](#))
- JPCM2 ([JPCM2, 1](#))
- JPCM3 ([JPCM3, 2](#))
- JDSD1 ([JDSD1, 5](#))
- JDSD2 ([JDSD2, 4](#))

Set the DIP switch [S/PDIF auto-detect](#) to Bypass (ON).

Last step: set the DIP switch [Input remapping](#) to OFF.

# Using the built-in Mux of the Buffalo III: the S/PDIF-4 Input Board

As a new feature, the Buffalo III now offers a built-in Mux unit. The Buffalo III's on-board firmware can select between 4 of the inputs by just using the external I/O connector ([EXT\\_IO, 12](#)). The easiest way to use this feature is to purchase the purpose built S/PDIF-4 Input Board.

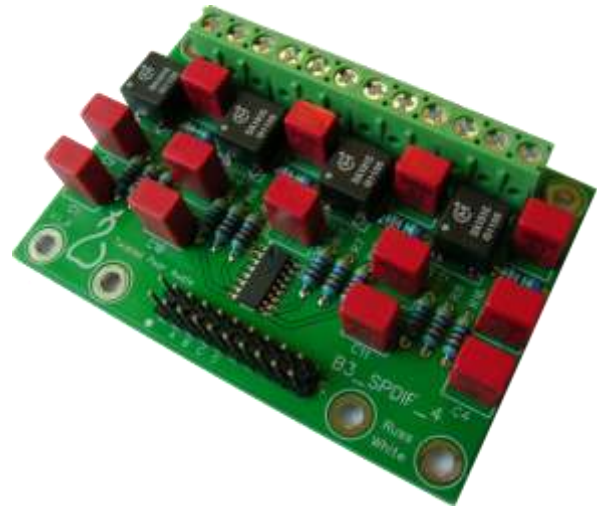

Beta V1.0 Input board

The kit includes a 4 channel input board, with a high speed (7 ns) quad comparator (a Maxim [MAX9201ESE+](#)), termination and galvanic isolation. It also includes a switch board to select the input, with LEDs that show the current input selection plus it includes connectors to neatly connect the input board to your Buffalo III board.

So in a single purchase, you now have 4 consumer level S/PDIF inputs, plus a Mux unit for 4 inputs for less than half of what the original 4:1 Mux board costed.

## Powering the board

The S/PDIF-4 Input Board is powered from the Buffalo III itself, by connecting the 5.25V input to the Buffalo III. The easy way to do this is to use a 20-pin ribbon cable from the S/PDIF-4 Input Board's 20-pin output connector to the Buffalo III's input connector ([DIN, 1](#)). The power supply that feeds the DAC board will then also feed the S/PDIF-4 Input Board. A shrouded 20-pin header and ribbon cable with IDC connector are included with the Buffalo III board for this purpose. The S/PDIF-4 Input Board comes with a suitable header and connector for the ribbon cable.

Note on inserting the flat cables: pin 1 is always marked with a dot (•). If you are using a color coded flat cable, the dot lines up with the red wire.

Under rare circumstances, the DAC may be experiencing problems locking on signals from the S/PDIF-4 Input Board. In many of those cases lowering the voltage to the S/PDIF-4 Input Board was the solution for this problem, or at the very least improved the situation. The easiest way to do this is by cutting the VD wires and one of the ground wires in the ribbon cable, and connecting them to another power supply.

## Plan the inputs

Please beware when building the S/PDIF-4 Input Board that careful planning is needed on how you would like to use your inputs, as each type of input requires it's own specific termination. You also need to take care when connecting the wires to the module, as unless your input type is AES/EBU you do not want to connect GND.

Below is the connection and termination scheme for the various types of inputs:

Input type	Connect + on module to	Connect - on module to	Connect GND on module to	R <sub>↔</sub>	RS <sub>↔</sub>
consumer level S/PDIF	+	-	Do NOT use	75Ω	0Ω
AES/EBU (<5V)	+ / hot	- / cold	GND (optional)	110Ω	0Ω
AES/EBU (<7V)*	+ / hot	- / cold	GND (optional)	54.9Ω	54.9Ω

\*The contents of your kit may vary. Older versions include 110Ω resistors, newer ones include other combinations.

So only for a balanced AES/EBU input you use the GND connector on the input block, for all other types of input you just use the + and – connectors of the S/PDIF-4 Input Board. Also note that although for AES/EBU the GND connection is marked as optional in the table, it is highly recommended you use it for this type of signal.

In the table  $R_{<z>}$  is the resistor R1 to R4 on the board. These resistors are linked to their corresponding input positions (INA to IND). See also the table: [Lay-out of S/PDIF-4 Input Board V1.1](#). So if you want to use a coax input on position C, you change the value of resistor R3 to 75Ω.

The value of  $RS_{<z>}$  only applies to version 1.1 S/PDIF-4 Input boards. The combination of the resistors  $R_{<z>}$  and  $RS_{<z>} = 54.9\Omega$  correctly terminates the input of AES/EBU input signals and at the same time is a voltage divider for signal levels that are too high for the comparator to handle. If you are using signal levels above 5V and your kit does not yet include these resistors, a suggested part for the 54.9Ω resistor can be found in the [extended bill of materials](#).

Note: As Twisted Pear Audio constantly tries to optimize the kit contents, there have been various sets of resistors for use with AES/EBU:

$R_{<z>}$	$RS_{<z>}$	Notes
110Ω	Not on PCB	version 1.0 of the PCB did not have $RS_{<z>}$
110Ω	Not included	From version 1.1 onwards, $RS_{<z>}$ was used. The first kits did not include a resistor, a wire bridge was suggested for $RS_{<z>}$
110Ω	0Ω	Next version included 0Ω resistors for all positions
56Ω	47Ω	First version to include 7V AES/EBU support
68Ω	43Ω	Better impedance match than the 56/47Ω set
54.9Ω	54.9Ω	Symetric setup, so resistors can't be accidentally swapped

### Switching between inputs

To switch between the inputs, the S/PDIF-4 Input Board uses the [2-bit Selector board](#). This 2-bit rotary switch module is connected to the external I/O connector ([EXT\\_IO, 12](#)). If you wish to use the LEDs that indicate the input in use, connect the 3.3V VDD pin to the switch module. Use the included 4-pin header to connect the following:

Connection	Switch board	EXT_IO pin
VDD	2	2
GND	4	4
Low bit	6	6
High bit	8	8

### S/PDIF-4 Input Board specification

Item	Value
Input voltage	5.25V DC
Power usage	± 20-30mA
Dimensions	3.05" x 2.087"
Dimensions (mm)	77.5 x 53 mm

## Lay-out of S/PDIF-4 Input Board V1.1

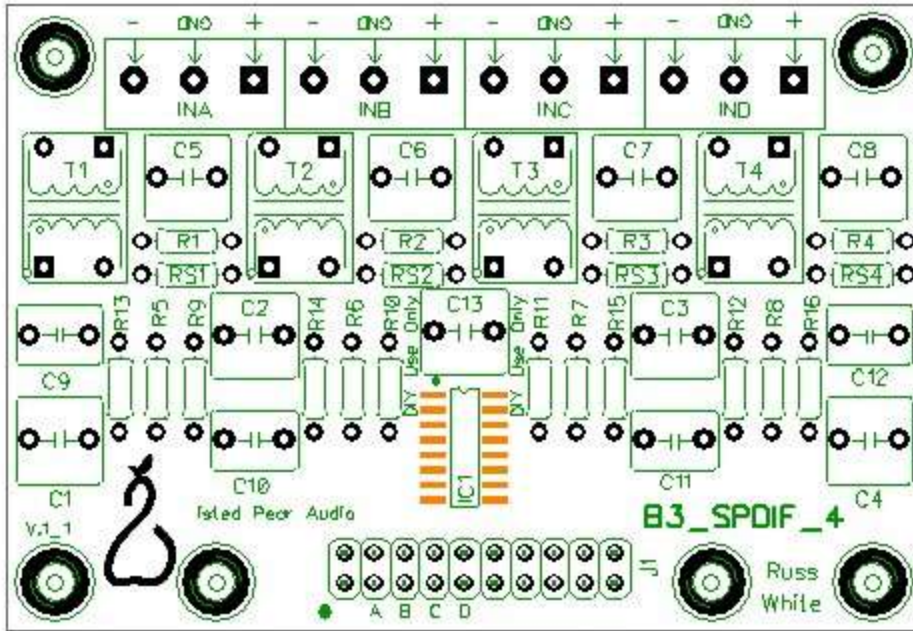

Input	Output	Input on DAC	Termination	Correction/bridge
INA	A	D1	R1	RS1
INB	B	D2	R2	RS2
INC	C	D3	R3	RS3
IND	D	D4	R4	RS4

# S/PDIF and PCM/DSD for the Buffalo III: Sidecar

For those that need multiple S/PDIF inputs but also want to connect a high resolution input like the new USB receiver module to the Buffalo III, there's a little add-on board for the S/PDIF-4 Input Board : Sidecar.

This module is plugged between the S/PDIF-4 Input Board and the Buffalo III, and switches between DSD or PCM (I2S) and the four S/PDIF inputs. It only supports stereo DSD and PCM signals, so no multi-channel input. But it's an easy way to add the USB receiver or another module which requires I2S output and still be able to use up to 4 S/PDIF inputs.



Like the input module, the Sidecar module needs to be fed 5.25V. Using another ribbon cable to plug the Sidecar module between the input module and the Buffalo III DAC board is the recommended way to apply power and at the same time get all the S/PDIF input and output pins connected on all the boards. When using a Placid HD check if the CCS current needs adjustment since both the input module and Sidecar draw some current from the power supply feeding the Buffalo III board. The DSD or PCM (I2S) signal is connected to the connector marked PCM/DSD, the 4 input lines are clearly marked on the board.

When using the Buffalo III with PCM or DSD sources, one should disable the S/PDIF autodetect feature of the ES9018 chipset. There are multiple ways of doing this:

## Use a dual pole single throw switch

- Connect pole 1 to GND and pin 14 (see [Appendix: Pin lay-out of the external I/O connector](#)) on the external I/O connector ([EXT\\_IO, 12](#)).
- Connect pole 2 to 5V and "B" on the Sidecar module. You can use the VD pin on the Sidecar as a source for 5V, or run a wire directly to your power supply.

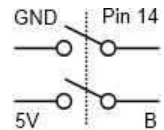

If you use this method, the switch will set the S/PDIF autodetect feature to disabled/bypass when the Sidecar is triggered to select the PCM/DSD input. Also, it allows use of all 4 positions of the input selection switch. This is the simplest method of achieving correct results.

## Use a microcontroller

Using a microcontroller like the AC2 is by far the most elegant solution, but it does require programming the microcontroller. It allows you to simply select the S/PDIF input and disable or enable the S/PDIF autodetect feature by setting registers in the ES9018 using the I2C bus. Based on fi. rotary encoder input you can select the correct S/PDIF input, and set the S/PDIF autodetect feature to the required value.

## Use one of the positions on the input selection switch

Normally the 2-bit rotary switch module uses a 4 position switch. If you wish to add the Sidecar module, you might want to use a 5 position switch, with the 5<sup>th</sup> position switching the Sidecar module. Or if only 3 or less of the S/PDIF inputs on the S/PDIF-4 Input Board are used, you might want to use one of the remaining positions to switch the Sidecar module. Since the S/PDIF autodetect feature also has to be put in the bypass position this method requires some extra work.

- Connect the B (Base) terminal on the Sidecar module to the corresponding off-board LED position ([on switch module: LEDs, 5](#)). It is even possible to leave the on-board LED in place if desired.
- Use a transistor with a suitable resistor connected to it's base to connect GND and pin 14 (see [Appendix: Pin lay-out of the external I/O connector](#)) on the external I/O connector ([EXT\\_IO, 12](#)) at the same time as you trigger B on the Sidecar.
- If required, change the value of R1 on the Sidecar module from 10K to 1K. A suggestion for this resistor can be found in the [extended bill of materials](#).

## Sidecar specification

Item	Value
<b>Input voltage</b>	5.25V DC
<b>Power usage</b>	± 65mA
<b>Dimensions</b>	2.3" x 1.525"
<b>Dimensions (mm)</b>	58.4 x 38.7 mm

# S/PDIF for the Buffalo III: Single S/PDIF Level Converter

For those users that only require a single S/PDIF input for the Buffalo III DAC board, there is a single S/PDIF consumer to TTL level converter board. This is a small converter, yet it maintains most of the functionality of the bigger S/PDIF-4 Input Board.

The input and output connectors have the spacing for a terminal block, plus the holes for 0.1" grid connectors. The board can be powered from the VD pin on the Buffalo III DAC board, just like the S/PDIF-4 Input Board.



Connector	Usage	Pins
IN	S/PDIF input	IN+, IN-
OUT/PWR	Power supply	VIN, GND
OUT/PWR	TTL level S/PDIF output	OUT, GND

For this board, R1 is the level resistor (like  $R_{S_{<z>}}$  is on the S/PDIF-4 Input Board) and R2 is the termination resistor (like  $R_{<z>}$  is on the S/PDIF-4 Input Board). For the correct values of these resistors see the table below.

Input type	IN+	IN-	R1	R2
consumer level S/PDIF	+	-	0Ω	75Ω
AES/EBU (<7V)*	+/hot	-/cold	54.9Ω	54.9Ω

\*The contents of your kit may vary.

See the chapter [Using the built-in Mux of the Buffalo III: the S/PDIF-4 Input Board](#) for other possible resistor combinations if your kit does not yet include the 54.9Ω resistors.

## Single S/PDIF Level Converter specification

Item	Value
Input voltage	5.25V DC
Power usage	<10mA typically
Dimensions	1.4" x 1.663"
Dimensions (mm)	35.6 x 42.2mm

# Preparing the Buffalo III board

## Preparing the Buffalo III board – first steps

Solder the input ([DIN, 1](#)) and power ([VD, 16](#)) connector blocks to the DAC. When using a Twisted Pear Audio I/V stage for either a stereo or dual mono setup, solder I/V stacking connectors to the underside of the DAC on the left and right output headers ([24 and 4](#)). Make sure you use the positions that are marked 03 and 04, as the other positions do not align with the TPA I/V stages.

Solder the lower half of the AVCC stacking connectors ([7 and 22](#)) on top of the DAC. Solder the upper half to the AVCC module.

If desired, solder the Lock ([LOCK, 9](#)) and Mute ([MUTE, 10](#)) LEDs in place. These were not mounted to allow mounting them to the front panel of the DAC using a (thin) wire.

If you don't want to use the on-board volume control, connect PB4 to the 3.3V pin on the ADC connector ([ADC, 15](#)). Otherwise, wire up the pot like described in [Adding volume control](#).

### Sidecar and S/PDIF-4 Input Board integration

If you want to use the Sidecar or S/PDIF-4 Input Board, remove any jumpers (if present) from:

- JPCM1 ([JPCM1, 3](#))
- JPCM2 ([JPCM2, 1](#))
- JPCM3 ([JPCM3, 2](#))
- JDSD1 ([JDSD1, 5](#))
- JDSD2 ([JDSD2, 4](#))

The jumpers are 0Ω SMD resistors (marked 000), that are included in the package.

If the source is connected directly to the DAC board, please read the previous chapter: [Connecting sources directly to the DAC board](#) and install the appropriate jumpers.

Solder the 24-pin unshrouded header for the EXT\_IO connector ([EXT\\_IO, 12](#)) in place. This allows you to connect the switch for the input selection of the S/PDIF-4 Input Board .

From this part onward, proceed to the chapter that is relevant for the board you're working on right now.

## Preparing the Buffalo III board for stereo operation

If you haven't done so, start with the [first steps](#). Then:

- Make sure the address header ([ADDR, 2](#)) is not shorted.
- Place the twelve jumpers J1-J12 ([J1-J12, 6-17](#)) at the underside of the board.
- Make sure R7 ([R7, 19](#)) is not shorted and L5 ([L5, 20](#)) is mounted.
- Make sure the on-board firmware controller ([IC8, 14](#)) is mounted.

For stereo, the following [DIP switch settings](#) are suggested:

Switch setting	Value
<b>Quantizer setting</b>	6-bits
<b>Normal/Dual mono selection</b>	Normal

Proceed to the final steps: [Preparing the board – final steps](#)

## Preparing the Buffalo III boards for dual mono operation

If you haven't done so, start with the [first steps](#).

### Preparing the left board

1. Make sure the address header ([ADDR, 2](#)) is not shorted.
2. Place the twelve jumpers J1-J12 ([J1-J12, 6-17](#)) at the underside of the board.
3. Make sure R7 ([R7, 19](#)) is not shorted and L5 ([L5, 20](#)) is mounted.
4. Make sure the on-board firmware controller ([IC8, 14](#)) is mounted.
5. If you want volume control, connect the pot like described in [Adding volume control](#).

Note: If mounting the pot to the right DAC board is much easier, swap the steps 3 to 5 between the right and left DAC board.

Only a DAC board with both the firmware controller and L5 in place and R7 not shorted will respond to the DIP switches. For dual mono, the following [DIP switch settings](#) are suggested:

Switch setting	Value
<b>Quantizer setting</b>	6-bits
<b>Normal/Dual mono selection</b>	Dual mono

### Preparing the right board

1. Put a jumper on the address header ([ADDR, 2](#)).
2. Place the twelve jumpers J1-J12 ([J1-J12, 6-17](#)) at the underside of the board.
3. Put a jumper on R7 ([R7, 19](#)) or remove L5 ([L5, 20](#)). Placing a jumper on R7 is the recommended solution, as it is easy to reverse while unsoldering L5 is usually more difficult and tiny SMD parts like L5 often get lost.
4. Remove the on-board firmware controller from the board ([IC8, 14](#)).
5. Connect the left and right boards by using the I2C header ([I2C, 17](#)). Connect only the SLA, SLC and GND pins of the I2C headers. Do **not** connect the 3.3V pins.

Proceed to the final steps: [Preparing the board – final steps](#)

## Preparing the Buffalo III board for multi channel operation

If you haven't done so, start with the [first steps](#). Then:

- Make sure the address header ([ADDR, 2](#)) is not shorted.

For multi channel, the following [DIP switch settings](#) are suggested:

Switch setting	Value
<b>Quantizer setting</b>	6-bits
<b>Normal/Dual mono selection</b>	Normal

### Combine outputs

The Buffalo III is equipped with a large amount of jumpers ([J1-J12, 6-17](#)) on the bottom of the board. In the standard configuration, these jumpers combine the outputs of the 8 individual DACs that are inside the ES9018 chip into 2 outputs. Although much more configurations are possible, these are some of the more common configurations:

Channels	J1	J2	J3	J4	J5	J6	J7	J8	J9	J10	J11	J12
<b>2</b>	√	√	√	√	√	√	√	√	√	√	√	√
<b>4</b>	√	√	√	√	-	-	√	√	√	√	-	-
<b>8</b>	-	-	-	-	-	-	-	-	-	-	-	-

√ = Place jumper, - = remove jumper

Please beware that besides joining outputs, one can also join inputs by using the JPCM1-3 and JDSD1-2 jumpers. This allows a flexible number of channels to be used.

Change the I/V stage as described in the chapter [Change I/V stage for multi-channel operation](#). Then proceed to the final steps: [Preparing the board – final steps](#)

## Change I/V stage for multi-channel operation

Using more than 2 outputs also means the I/V stages receive less input than before. So when using an IVY III or Legato 3.1 in this configuration, the I/V stages should be altered slightly to counter the effect of receiving just ¼ of the normal input signal. Below you'll find the list of changes for the most commonly used I/V stages. The values for the parts are not critical.

### IVY III changes

On the IVY III the resistors R1 to R4 need to be altered. The calculation of the new value is simple:

$$R = \frac{3000}{\text{amount of parallel output channels of Buffalo III}}$$

An example: in the normal stereo mode, the DAC board combines 4 of it's outputs into 1 input of the IVY III. So in this case, one uses the standard value for the resistors R1 to R4, which is 750Ω.

Channels	Value for R1-R4
<b>2 (default)</b>	750Ω
<b>4</b>	~1.5KΩ
<b>8</b>	~3KΩ

### Legato 3.1 changes

On the Legato 3.1 more needs to be changed if you want to change both the balanced and the single ended outputs:

Position	Value for multi channel configuration
<b>R1-R4</b>	$R = \frac{600}{\text{amount of parallel output channels of Buffalo III}}$
<b>R9-R16</b>	$R = \frac{2720}{\text{amount of parallel output channels of Buffalo III}}$
<b>C1-C4</b>	Alter filtering according to table

This leads to the following values:

Channels	R1-R4	R9-R16	C1-C4
<b>2 (default)</b>	150Ω	680Ω	2.2nf
<b>4</b>	~300Ω	~1.36KΩ	~1nf
<b>8</b>	~600Ω	~2.72KΩ	~500pf

If only the single ended outputs are used, one can just change the SE gain by altering the resistors R17-R20.

Channels	R17-R20
<b>2 (default)</b>	4.99Ω
<b>4</b>	~2.5KΩ
<b>8</b>	~1.25KΩ

Please note that either the SE gain or the total gain should be altered, but not both.

### Placement of I/V stages

It is important to place the I/V stages close to the outputs of the Buffalo III board. The easiest way of doing this for multiple I/V stages is to stack them on top of each other right next to the left and right outputs of the DAC board. Then route wire from the outputs of the left and right side of the DAC board to the input connectors.

## Preparing the Buffalo III board – final steps

For each board:

- Mount the Trident regulator modules (see: [Adding the Trident regulator](#)).
- Attach the AVCC to the DAC. Make sure the AVCC module is mounted correctly: the pears on both the AVCC and Buffalo III boards should point in the same direction (see picture).
- Connect the inputs.
- Stack the board on top of the I/V stage or connect the outputs.
- After testing the power supply, hook up the power.

And for boards with an on-board firmware

- If you are using the S/PDIF-4 Input Board: connect the 2-bit rotary switch module.
- Set the remaining [DIP switch settings](#) as you wish, in general these work best:

Switch setting	Value
Differential mode	True
FIR roll off mode	Fast
DPLL bandwidth	Default
DPLL bandwidth multiplier	1x
S/PDIF input selection	D1
Oversampling filter and reclocking	Use

- When using the Sidecar module, set the DIP switch [Input remapping](#) to ON:

Switch setting	Value
Input remapping	ON

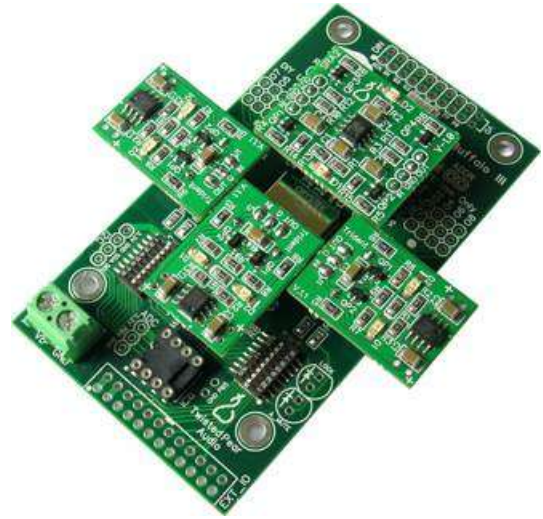

## Buffalo III DIP switch settings

The Buffalo III DAC board is extremely versatile: it has 16 user-configurable settings which is far more than any of the previous versions. Even with this amount of flexibility however, it still does not allow for all configuration options of the ES9018 DAC chip. For specialized setups, it is possible Twisted Pear Audio will release alternative firmware chips much like they did with the Buffalo II. This means this chapter is highly dependent on the firmware chosen.

For now this chapter is based on the standard firmware as shipped with the Buffalo III. Please beware that if you are using a different firmware, these switches might have a totally different meaning.

Note: Setting the switches is not optional: when it is shipped the default setting on a Buffalo III board has all DIP switch settings set to ON. While this might work in some cases, it will prevent the usage of the S/PDIF-4 Input board. Also DPLL settings are then set to their highest value. The recommended settings are almost always OFF as displayed (under the label Default) in the tables in the next paragraph, with a few exceptions, which depend on the situation.

### Switch settings summary

The DIP switches SW1 ([SW1, 18](#)) and SW2 ([SW2, 11](#)) are used to set the boards configuration and features. Power need not be cycled after changing these switches.

For DIP switch block SW1:

Switch	Default	EXT_IO	Usage	OFF	ON
1	OFF	A0	<a href="#">Quantizer setting</a> (combined: 1 with 2)		
2	OFF	A1	Quantizer setting (combined: 1 with 2)		
3	OFF	A2	<a href="#">Differential mode</a>	True	Pseudo
4	OFF	A3	<a href="#">FIR roll off mode</a>	Fast	Slow
5	OFF	A4	<a href="#">DPLL bandwidth</a> (combined: 5 to 7)		
6	OFF	A5	DPLL bandwidth (combined: 5 to 7)		
7	OFF	A6	DPLL bandwidth (combined: 5 to 7)		
8	OFF	A7	DPLL bandwidth multiplier	1x	128x

For DIP switch block SW2:

Switch	Default	EXT_IO	Usage	OFF	ON
1	OFF	B0	<a href="#">S/PDIF input selection</a> (combined: 1 with 2)		
2	OFF	B1	S/PDIF input selection (combined: 1 with 2)		
3		B2	<a href="#">Normal/Dual mono selection</a>	Normal	Dual mono
4	OFF	B3	<a href="#">Oversampling filter and reclocking</a>	Use	Bypass
5	OFF	B4	<a href="#">S/PDIF auto-detect</a>	Use	Bypass
6	OFF	B5	<a href="#">IIR Bandwidth</a> (combined: 6 with 7)		
7	OFF	B6	IIR Bandwidth (combined: 6 with 7)		
8		B7	<a href="#">Input remapping</a>	OFF	ON

## Quantizer setting

The Quantizer settings will allow the editing of the number of bits each quantizer will use. Depending on the number of channels of audio, the quantizers can use anywhere between 6 and 9 bits. When running in stereo mode (2 channels) it is possible for 9 bits, with 4 channels it is possible for 8 bits and in 8-channel mode, either 7 or 6 bits are possible.

Channels	6	7	8	9
2	√	√	√	√
4	√	√	√	-
8	√	√	-	-

Set the quantizer to the value you desire.

Quantizer	SW1:1	SW1:2
6 bits	OFF	OFF
7 bits	ON	OFF
8 bits	OFF	ON
9 bits	ON	ON

The best measured performance is reached when the quantizer is set to 6-bits, and differential is set to True.

## Differential mode

Changes the differential mode from pseudo to true, and vice versa. This is useful if a higher bit quantizer is desired but normally not possible.

### 8 channel settings

Quantizer	Differential	Notes
6	True	Routes 6 bits to the internal DAC part connected to + (dac) and the exact same 6 bits inverted to the part connected to - (dacB). This is what 'true differential' means.
7	Pseudo	Routes ½ of the 7 bits to the internal dac (6 bits) and the other half of the 7 bits <u>inverted</u> to dacB. Note that the bits are no longer identical and you now need the difference of the 2 for the correct signal. This mode should give lower quantization noise in theory, and may even 'sound better' but the ESS DNR measurement was about 0.5dB to 1dB worse than the true differential mode and 6 bit quantizers.

### Stereo settings

In stereo mode the DAC needs to be fed the same signal to some of the left and right inputs. This can be done by physically joining the input pins or by letting the DAC remap some of the inputs internally (See: [Input remapping](#)). The table below shows which inputs need to be fed the same signal for the various quantizer and differential settings.

Quantizer	Differential	Join left inputs	Join right inputs
6	True	1,3,5 and 7	2,4,6 and 8
7	Pseudo	1,3,5 and 7	2,4,6 and 8
7	True	1 and 5	2 and 6
8	Pseudo	1 and 5	2 and 6
8	True	1	2
9	Pseudo	1	2

## FIR roll off mode

The FIR roll off selects between two sets of FIR coefficients. One with a slow roll off and one with a sharp roll off. Some will prefer one or the other. Try both and see which you like best. You can look at the ESS datasheet for more information.

## DPLL bandwidth

Increasing this value will allow the DAC to get a lock to the incoming signal much easier, but at the same time it will allow more jitter to pass through.

When in doubt, use the 'Default' setting. In 'Default' mode the DAC attempts to set the DPLL bandwidth automatically. However if the jitter is varying wildly the DAC may get confused when used in this setting. In that case setting the bandwidth manually using these switches will usually solve the issue.

DPLL bandwidth	SW1:5	SW1:6	SW1:7
Default	OFF	OFF	OFF
Lowest	ON	OFF	OFF
Low	OFF	ON	OFF
Low-medium	ON	ON	OFF
Medium	OFF	OFF	ON
Medium-high	ON	OFF	ON
High	OFF	ON	ON
Highest	ON	ON	ON

## S/PDIF input selection

Set these switches to OFF when using the EXT\_IO connector ([EXT\\_IO, 12](#)). This allows the external switch connected to this port to control the input selection.

Input selected	SW2:1	SW2:2
D1	OFF	OFF
D2	OFF	ON
D3	ON	OFF
D4	ON	ON

## Normal/Dual mono selection

In dual mono mode the channel on the DAC which is opposite of the selected channel carries the same analog signal but in anti-phase as shown in the table below. This allows the use of the IVY III or Legato 3.1 as a single differential (balanced) mono channel.

Mode	Left Differential Output	Right Differential Output
Normal	Normal Phase	Normal Phase
Mono – Left	Normal Phase	Anti-Phase
Mono – Right	Anti-Phase	Normal Phase

Dual mono operation is used to achieve the best dynamic range. If you still need single ended output then you would want to add a high quality BAL/SE converter such as the Ballsie Lite, Ventus or Ventus EZ.

For more details about the IVY III or Legato 3.1 please check their manuals.

## Oversampling filter and reclocking

Setting this switch to 'bypass' disables the oversampling and reclocking (jitter reduction) feature of the ES9018. Do not disable jitter reduction unless your transport uses an excellent clock.

### S/PDIF auto-detect

Normally the ES9018 selects the signal type all by itself. With some very high speed PCM sources, the autodetection mechanism does not work properly. In this case, use the bypass mode.

### IIR Bandwidth

The default setting 'Normal' should give the best performance when using PCM (least in-bound ripple). When using DSD you may want to try higher values.

Meaning	SW2:6	SW2:7
Normal (for PCM)	OFF	OFF
50k (for DSD)	OFF	ON
60k (for DSD)	ON	OFF
70k (for DSD)	ON	ON

### Input remapping

This setting enables the use of the Sidecar module by remapping the inputs of the internal DACs. When ON it maps the DACs 1, 2, 5, and 6 to the DACs 3,4,7, and 8 respectively.

## Buffalo III specification

Item	Value
Max. Input signal	32 bit / 400KHz
Input voltage	5 ~ 5.5V DC, 5.25V DC recommended
Power usage with Trident set	±440mA
Channels	1-8
DAC Output current	4mA per channel, 16mA per side when combined
Max. current supplied by I2C header	75mA
I2C voltage	3.3V (5V tolerant)
Output impedance	781 Ω per channel, 195Ω per side when combined
Dynamic range (mono mode)	135dB
THD+N (with IVY III, mono mode)	-120dB
Dimensions	3.7" x 2.1" Note: the mounting holes are exactly the same as the Buffalo II
Dimensions (mm)	94 x 53.3 mm



	Marked	Description	Pins	Pitch
1	DIN	Digital Input connector	2x10	0.1"
2	ADDR	Address jumper	1x2	0.1"
3	02	2nd Output header	1x3	0.1"
4	04	4th Output header Note: connector for I/V stage	1x3	0.1"
5	06	6th Output header	1x3	0.1"
6	08	8th Output header	1x3	0.1"
7	VD/GND/AVCC/DVCC	AVCC header – right side	1x4	0.1"
8	VDD	VDD header		
9	LOCK	Lock LED header	1x2	0.1"
10	A_MUTE	Mute LED header	1x2	0.1"
11	SW2	Second block of DIP switches		
12	EXT_IO	External I/O connector	2x12	0.1"
13	VDD_XO/GND/VD	VDD_XO header	1x3	0.1"
14	IC8	Firmware controller		
15	ADC	ADC header	1x3	0.1"
16	VD/GND	Power input		
17	I2C	I2C header	1x4	0.1"
18	SW1	First block of DIP switches		
19	R7	Port expander address jumper		
20	L5	Power connection for port expander section of ES9018		
21	DVCC	DVCC header	1x3	0.1"
22	DVCC/AVCC/GND/VD	AVCC header – left side	1x4	0.1"
23	01	1st Output header	1x3	0.1"
24	03	3rd Output header Note: connector for I/V stage	1x3	0.1"
25	05	5th Output header	1x3	0.1"
26	07	7th Output header	1x3	0.1"
27	RESET	Reset header	1x2	0.1"



	Marked	Description
1	JPCM2	Jumper 2 for PCM stereo mode, joins inputs D2 and D3
2	JPCM3	Jumper 3 for PCM stereo mode, joins inputs D3 and D4
3	JPCM1	Jumper 1 for PCM stereo mode, joins inputs D4 and D5
4	JDSD2	Jumper 2 for DSD, joins inputs D1 and D5
5	JDSD1	Jumper 1 for DSD, joins inputs D2 and D6
6	J12	Jumper for combining + of outputs 03 and 05
7	J9	Jumper for combining + of outputs 05 and 07
8	J8	Jumper for combining + of outputs 01 and 03
9	J7	Jumper for combining - of outputs 01 and 03
10	J10	Jumper for combining - of outputs 05 and 07
11	J11	Jumper for combining - of outputs 03 and 05
12	J1	Jumper for combining - of outputs 02 and 04
13	J5	Jumper for combining - of outputs 04 and 06
14	J4	Jumper for combining - of outputs 06 and 08
15	J2	Jumper for combining + of outputs 02 and 04
16	J3	Jumper for combining + of outputs 06 and 08
17	J6	Jumper for combining + of outputs 04 and 06

## Pin lay-out of the Buffalo III digital input connector

GND	GND	GND	GND	GND	GND	GND	GND	GND	VD
2	4	6	8	10	12	14	16	18	20
1	3	5	7	9	11	13	15	17	19
DCK	D1	D2	D3	D4	D5	D6	D7	D8	VD

Pin	Marked	Description
1	DCK	
2		Ground connector
3	D1	
4		Ground connector
5	D2	
6		Ground connector
7	D3	
8		Ground connector
9	D4	
10		Ground connector
11	D5	
12		Ground connector
13	D6	
14		Ground connector
15	D7	
16		Ground connector
17	D8	
18		Ground connector
19	VD	Power supply pin for powering external boards
20	VD	Power supply pin for powering external boards

# The Buffalo IIISE Board

*SE for Stereo Edition*

The following chapters handle the instructions and modules for the Buffalo IIISE DAC board. Go to [Adding Inputs/Modules](#) when you have a Buffalo III DAC board to continue reading.

# Input options for the Buffalo IIISE DAC module

The Buffalo IIISE DAC board is an optimized version for stereo. Unlike the Buffalo III, it does not expose all 8 digital inputs of the ES9018 chip. Instead (like the Buffalo II board) it has an on-board comparator. So there is no need for level conversion like the Single S/PDIF Level Converter.

## Switching signals

Quite unlike the Buffalo II, the Buffalo IIISE is not limited to just consumer level S/PDIF or TTL level S/PDIF, I2S or DSD. Both types of signals can be connected at the same time. It's much like having a Buffalo III board, with built-in Sidecar and Single S/PDIF Level Converter. The active input signal can be selected by connecting a switch to the switch pad ([IP\\_S, 3](#)) or by an external controller:

Input	Switch	Controller	Pins
<b>S/PDIF</b>	Open	High	SPDIF, GND
<b>PCM/DSD</b>	Closed	Low	DCK, D1, D2, GND

## Input limitations

When using high resolution sources I2S input is preferred, as unlike the S/PDIF input it is not limited to 24-bit / 192KHz. Keep I2S wires as short as possible, and when using dual mono mode make sure the I2S wires are of equal length to eliminate timing issues. In short:

Input	Channels	Notes
<b>Consumer S/PDIF</b>	2	Limited to 24-bit / 192KHz. Connect to S/PDIF and GND.
<b>TTL Level S/PDIF</b>	2	Limited to 24-bit / 192KHz. Connect to D1 and GND.
<b>PCM (I2S)</b>	2	Keep wires short or use the <a href="#">Teleporter</a> module
<b>DSD</b>	1 to 2	

# Connecting sources directly to the Buffalo IIISE DAC board

Compared to the Buffalo III module, it is easier to connect digital sources directly to the Buffalo IIISE DAC board.

## Consumer level S/PDIF

For consumer level S/PDIF the following connections are possible, stereo only:

Source connection	DIN ( <a href="#">DIN, 1</a> )
+	S/PDIF
-	GND

## TTL level S/PDIF

For TTL level S/PDIF the following connections are possible, stereo only:

Source connection	DIN ( <a href="#">DIN, 1</a> )
+	D1
-	GND

## TTL level PCM

The Buffalo IIISE DAC board also supports TTL level PCM (I2S by default), which can only be stereo:

Source connection	DIN ( <a href="#">DIN, 1</a> )	Channel
Bit clock	DCK	
Word clock(LRCK)	D1	
Data	D2	1 and 2
GND	GND	

## TTL level DSD

And the Buffalo IIISE DAC board supports 2-channel TTL level DSD:

Source connection	DIN ( <a href="#">DIN, 1</a> )
Bit clock	DCK
Data 1	D1
Data 2	D2
GND	GND

# Preparing the Buffalo IIISE board

## Preparing the Buffalo IIISE board – first steps

Solder the input ([DIN, 1](#)) and power ([VD, 16](#)) connector blocks to the DAC. When using a Twisted Pear Audio I/V stage for either a stereo or dual mono setup, solder I/V stacking connectors to the underside of the DAC on the left and right output headers ([23 and 4](#)).

Solder the lower half of the AVCC stacking connectors ([5 and 22](#)) on top of the DAC. Solder the upper half to the AVCC module.

If desired, solder the Lock ([LOCK, 9](#)) and Mute ([MUTE, 10](#)) LEDs in place. These were not mounted to allow mounting them to the front panel of the DAC using a (thin) wire.

If you don't want to use the on-board volume control, connect PB4 to the 3.3V pin on the ADC connector ([ADC, 15](#)). Otherwise, wire up the pot like described in [Adding volume control](#).

If the source is connected directly to the DAC board, please read the chapter: [Connecting sources directly to the Buffalo IIISE DAC board](#) and install the appropriate jumpers.

Optional: solder the 24-pin unshrouded header for the EXT\_IO connector ([EXT\\_IO, 12](#)) in place.

From this part onward, proceed to the chapter that is relevant for the board you're working on right now.

## Preparing the Buffalo IIISE board for stereo operation

If you haven't done so, start with the [first steps](#). Then:

- Make sure the address header ([ADDR, 2](#)) is not shorted.
- Make sure R7 ([R7, 19](#)) is not shorted and L5 ([L5, 20](#)) is mounted.
- Make sure the on-board firmware controller ([IC8, 14](#)) is mounted.

For stereo, the following [DIP switch settings](#) are suggested:

Switch setting	Value
<b>Quantizer setting</b>	6-bits
<b>Normal/Dual mono selection</b>	Normal

Proceed to the final steps: [Preparing the board – final steps](#)

## Preparing the Buffalo III/IISE boards for dual mono operation

If you haven't done so, start with the [first steps](#).

### Preparing the left board

1. Make sure the address header ([ADDR, 2](#)) is not shorted.
2. Make sure R7 ([R7, 19](#)) is not shorted and L5 ([L5, 20](#)) is mounted.
3. Make sure the on-board firmware controller ([IC8, 14](#)) is mounted.
4. If you want volume control, connect the pot like described in [Adding volume control](#).

Note: If mounting the pot to the right DAC board is much easier, swap the steps 2 to 4 between the right and left DAC board.

Only a DAC board with both the firmware controller and L5 in place and R7 not shorted will respond to the DIP switches. For dual mono, the following [DIP switch settings](#) are suggested:

Switch setting	Value
<b>Quantizer setting</b>	6-bits
<b>Normal/Dual mono selection</b>	Dual mono

### Preparing the right board

1. Put a jumper on the address header ([ADDR, 2](#)).
2. Put a jumper on R7 ([R7, 19](#)) or remove L5 ([L5, 20](#)). Placing a jumper on R7 is the recommended solution, as it is easy to reverse while unsoldering L5 is usually more difficult and tiny SMD parts like L5 often get lost.
3. Remove the on-board firmware controller from the board ([IC8, 14](#)).
4. Connect the left and right boards by using the I2C header ([I2C, 17](#)). Connect only the SLA, SLC and GND pins of the I2C headers. Do **not** connect the 3.3V pins.

Proceed to the final steps: [Preparing the board – final steps](#)

## Preparing the Buffalo III/IISE board – final steps

For each board:

- Mount the Trident regulator modules (see: [Adding the Trident regulator](#)).
- Attach the AVCC to the DAC. Make sure the AVCC module is mounted correctly: the pears on both the AVCC and Buffalo III boards should point in the same direction (see picture).
- Connect the inputs.
- Stack the board on top of the I/V stage or connect the outputs.
- After testing the power supply, hook up the power.

And for boards with an on-board firmware

- If you are using the S/PDIF-4 Input Board: connect the 2-bit rotary switch module.
- Set the remaining [DIP switch settings](#) as you wish, in general these work best:

Switch setting	Value
Differential mode	True
FIR roll off mode	Fast
DPLL bandwidth	Default
DPLL bandwidth multiplier	1x
Oversampling filter and reclocking	Use

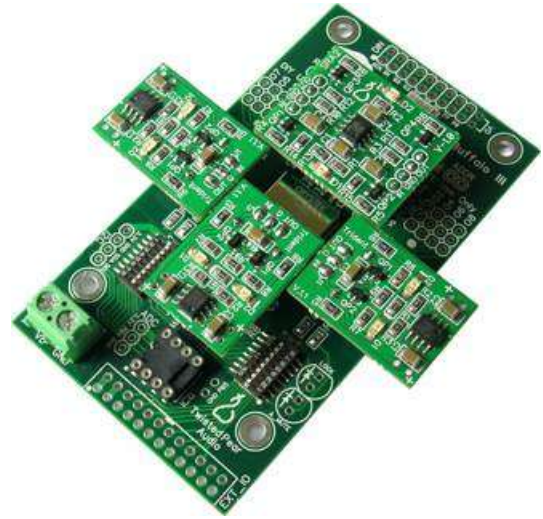

# Buffalo IIISE DIP switch settings

The Buffalo IIISE DAC board is extremely versatile: like the Buffalo III it has 16 user-configurable settings which is far more than any of the previous versions. Even with this amount of flexibility however, it still does not allow for all configuration options of the ES9018 DAC chip. For specialized setups, it is possible Twisted Pear Audio will release alternative firmware chips much like they did with the Buffalo II. This means this chapter is highly dependent on the firmware chosen.

For now this chapter is based on the standard firmware as shipped with the Buffalo IIISE. Please beware that if you are using a different firmware, these switches might have a totally different meaning.

Note: Setting the switches on the Buffalo IIISE board is often optional: when it is shipped the Buffalo IIISE board has all DIP switch settings set to ON. This should work in most cases.

## Switch settings summary

The DIP switches SW1 ([SW1, 18](#)) and SW2 ([SW2, 11](#)) are used to set the boards configuration and features. Power need not be cycled after changing these switches.

For DIP switch block SW1:

Switch	Default	EXT_IO	Usage	ON	OFF
1	ON	A0	<a href="#">Quantizer setting</a> (combined: 1 with 2)		
2	ON	A1	Quantizer setting (combined: 1 with 2)		
3	ON	A2	<a href="#">Differential mode</a>	True	Pseudo
4	ON	A3	<a href="#">FIR roll off mode</a>	Fast	Slow
5	ON	A4	<a href="#">DPLL bandwidth</a> (combined: 5 to 7)		
6	ON	A5	DPLL bandwidth (combined: 5 to 7)		
7	ON	A6	DPLL bandwidth (combined: 5 to 7)		
8	ON	A7	DPLL bandwidth multiplier	1x	128x

For DIP switch block SW2:

Switch	Default	EXT_IO	Usage	ON	OFF
1	ON	B0	<a href="#">PCM input type</a> (combined: 1 to 3)		
2	ON	B1	PCM input type (combined: 1 to 3)		
3	ON	B2	PCM input type (combined: 1 to 3)		
4		B3	<a href="#">Stereo/Dual mono selection</a>	Stereo	Dual mono
5	ON	B4	<a href="#">Oversampling filter and reclocking</a>	Use	Bypass
6	ON	B5	<a href="#">S/PDIF auto-detect</a>	Use	Bypass
7	ON	B6	<a href="#">IIR Bandwidth</a> (combined: 7 with 8)		
8	ON	B7	IIR Bandwidth (combined: 7 with 8)		

## Quantizer setting

The Quantizer settings will allow the editing of the number of bits each quantizer will use. This number can be between 6 and 9 bits. Set the quantizer to the value you desire.

Quantizer	SW1:1	SW1:2
6 bits	ON	ON
7 bits	OFF	ON
8 bits	ON	OFF
9 bits	OFF	OFF

The best measured performance is reached when the quantizer is set to 6-bits, and differential is set to True.

## Differential mode

Changes the differential mode from pseudo to true, and vice versa. This is useful if a higher bit quantizer is desired but normally not possible.

## FIR roll off mode

The FIR roll off selects between two sets of FIR coefficients. One with a slow roll off and one with a sharp roll off. Some will prefer one or the other. Try both and see which you like best. You can look at the ESS datasheet for more information.

## DPLL bandwidth

Increasing this value will allow the DAC to get a lock to the incoming signal much easier, but at the same time it will allow more jitter to pass through.

When in doubt, use the 'Default' setting. In 'Default' mode the DAC attempts to set the DPLL bandwidth automatically. However if the jitter is varying wildly the DAC may get confused when used in this setting. In that case setting the bandwidth manually using these switches will usually solve the issue.

DPLL bandwidth	SW1:5	SW1:6	SW1:7
Default	ON	ON	ON
Lowest	OFF	ON	ON
Low	ON	OFF	ON
Low-medium	OFF	OFF	ON
Medium	ON	ON	OFF
Medium-high	OFF	ON	OFF
High	ON	OFF	OFF
Highest	OFF	OFF	OFF

## PCM input type

Set these switches to select the type of input signal that is connected to the digital input connector ([DIN.1](#)):

Input	SW2:1	SW2:2	SW2:3
I2S	ON	ON	ON
Left justified (up to 32 bits)	ON	ON	OFF
Right justified – 32 bit	OFF	ON	ON
Right justified – 24 bit	OFF	ON	OFF
Right justified – 20 bit	OFF	OFF	ON
Right justified – 16 bit	OFF	OFF	OFF

## Stereo/Dual mono selection

In dual mono mode the channel on the DAC which is opposite of the selected channel carries the same analog signal but in anti-phase as shown in the table below. This allows the use of the IVY III or Legato 3.1 as a single differential (balanced) mono channel.

Mode	Left Differential Output	Right Differential Output
<b>Normal</b>	Normal Phase	Normal Phase
<b>Mono – Left</b>	Normal Phase	Anti-Phase
<b>Mono – Right</b>	Anti-Phase	Normal Phase

Dual mono operation is used to achieve the best dynamic range. If you still need single ended output then you would want to add a high quality BAL/SE converter such as the Ballsie Lite, Ventus or Ventus EZ.

For more details about the IVY III or Legato 3.1 please check their manuals.

## Oversampling filter and reclocking

Setting this switch to 'bypass' disables the oversampling and reclocking (jitter reduction) feature of the ES9018. Do not disable jitter reduction unless your transport uses an excellent clock.

## S/PDIF auto-detect

Normally the ES9018 selects the signal type all by itself. With some very high speed PCM sources, the autodetection mechanism does not work properly. In this case, use the bypass mode.

## IIR Bandwidth

The default setting 'Normal' should give the best performance when using PCM (least in-bound ripple). When using DSD you may want to try higher values.

Meaning	SW2:7	SW2:8
<b>Normal (for PCM)</b>	ON	ON
<b>50k (for DSD)</b>	ON	OFF
<b>60k (for DSD)</b>	OFF	ON
<b>70k (for DSD)</b>	OFF	OFF

## Buffalo IIISE specification

Item	Value
Max. Input signal	32 bit / 400KHz
Input voltage	5 ~ 5.5V DC, 5.25V DC recommended
Power usage with Trident set	±440mA
Channels	1-2
DAC Output current	16mA per side
Max. current supplied by I2C header	75mA
I2C voltage	3.3V (5V tolerant)
Output impedance	195Ω per side
Dynamic range (mono mode)	135dB
THD+N (with IVY III, mono mode)	-120dB
Dimensions	3.7" x 2.1" Note: the mounting holes are exactly the same as the Buffalo II
Dimensions (mm)	94 x 53.3 mm

# Lay-out of Buffalo III SE module

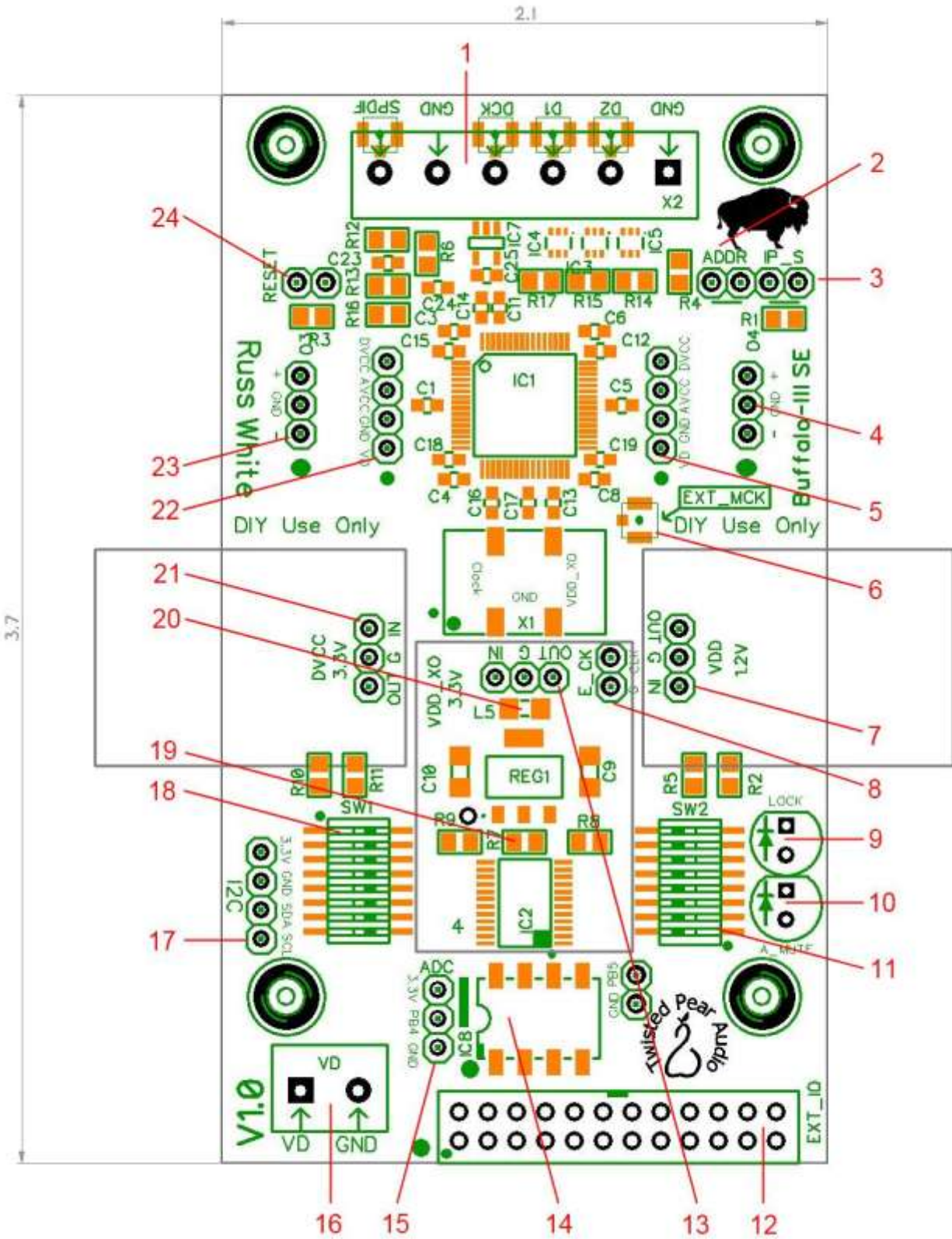

Marked	Description	Pins	Pitch
1	DIN	Digital Input connector	
2	ADDR	Address jumper	1x2 0.1"
3	IP_S	Input switch for DIN signal	1x2 0.1"
4	04	"4 <sup>th</sup> " Output header Note: connector for I/V stage	1x3 0.1"
5	VD/GND/AVCC/DVCC	AVCC header – right side	1x4 0.1"
6	EXT_MCK	uFL connector for external master clock	
7	VDD	VDD header	1x3 0.1"
8	E_CK	connector for external master clock	1x2 0.1"
9	LOCK	Lock LED header	1x2 0.1"
10	A_MUTE	Mute LED header	1x2 0.1"
11	SW2	Second block of DIP switches	
12	EXT_IO	External I/O connector	2x12 0.1"
13	VDD_XO/GND/VD	VDD_XO header	1x3 0.1"
14	IC8	Firmware controller	
15	ADC	ADC header	1x3 0.1"
16	VD/GND	Power input	
17	I2C	I2C header	1x4 0.1"
18	SW1	First block of DIP switches	
19	R7	Port expander address jumper	
20	L5	Power connection for port expander section of ES9018	
21	DVCC	DVCC header	1x3 0.1"
22	DVCC/AVCC/GND/VD	AVCC header – left side	1x4 0.1"
23	03	"3 <sup>rd</sup> " Output header Note: connector for I/V stage	1x3 0.1"
24	RESET	Reset header	1x2 0.1"

## Pin lay-out of the Buffalo IIISE digital input connector

S/PDIF	GND	DCK	D1	D2	GND
1	2	3	4	5	6

Pin	Marked	Description
1	S/PDIF	Consumer level input: goes through on-board comparator
2	GND	Ground connector
3	DCK	
4	D1	
5	D2	
6	GND	Ground connector

# Adding Inputs/Modules

The following chapters handle the instructions and modules that are common to the Buffalo III/IIISE DAC boards.

## Adding COAX input

Coax is a popular way to feed a S/PDIF signal to the Buffalo-series DAC boards, but again: for the Buffalo III you need to feed it a TTL level S/PDIF signal, or pass it through a comparator like the one used on the S/PDIF-4 Input Board or the Single S/PDIF Level Converter. On the Buffalo IIISE, you can connect this signal directly to the GND and SP/DIF pins on the DIN connector.

Although RCA connectors are often used as a coax connector, please beware that these are rarely of true 75Ω impedance. To avoid reflections due to impedance differences, instead of using RCA it's better to use a true 75Ω BNC chassis connector on both ends, along with a 75Ω coax connection cable. There are several types of chassis connectors, but whatever connector you choose: make sure it is 75Ω impedance. Suggestions for connectors can be found in the [extended bill of materials](#).

# Adding AES/EBU input

AES/EBU is best known as a balanced, 110Ω terminated digital input. The standard connector used for this digital input is a 3-pin XLR female chassis part.

When wiring the connector it is recommend you follow the EIA Standard RS-297-A XLR lay-out:

Pin	Function
1	Ground (cable shield)
2	Positive (hot)
3	Negative (cold)



Note: By convention, XLR inputs are female and XLR outputs are male. An exception are the balanced XLR connectors for headphone outputs: after-market balanced headphone cables are often fitted with two 3-pin male XLR connectors, which of course means one has to fit female XLR chassis parts to use these cables.

## AES/EBU on the Buffalo III board

AES/EBU can't be connected directly to the Buffalo III DAC board. One should use a level converter like the S/PDIF-4 Input Board or the Single S/PDIF Level Converter. AES/EBU can be connected to any of the inputs of the S/PDIF-4 Input Board, but some parts need to be changed.

AES/EBU works fine on the S/PDIF-4 Input Board V1.0 for signals of up to 5Vpp. Signals of more than 5Vpp have not been tested, they might work. If your signal is hotter than 5Vpp and does not work correctly with board version 1.0, cut the trace between the input transformer and R<Z> and insert a resistor to pad it down.

On board version 1.1 of the S/PDIF-4 Input Board, the resistors RS1 to RS4 can be used to lower the voltage of the AES/EBU signal if the signal voltage is above 5V. If the voltage is below 5V or when using other input types one can bridge the positions RS1 to RS4 with some wire or the 0Ω resistors that are included in later versions of the package. The very latest version of the kit includes 2 54.9Ω resistors which makes it suitable for all AES/EBU signal levels. For more information see the paragraph [Built-in Mux: the S/PDIF-4 Input Board](#).

## AES/EBU on the Buffalo IIISE board

AES/EBU can't be connected directly to the Buffalo IIISE DAC board either. You need an external solution, like a 1:1 transformer plus voltage divider or a 2:1 transformer plus a DC blocking cap at the primary. Another way to add AES/EBU is to add the [S/PDIF 4:1 MUX/Receiver](#) and use it's AES/EBU input.

# Adding USB input

For USB input, a USB Receiver is available. The USB receiver module offers S/PDIF and I2S output. There are two versions of the USB receiver: the first generation is based on the Texas Instruments PCM2707 USB DAC chip. This version is limited to 16-bit / 48KHz signals. The latest generation is based on an XMOS controller, and allows up to 32-bit / 384KHz. It is expected to be available in the 2012/2013 timeframe.

## Lay-out of the Opus USB receiver

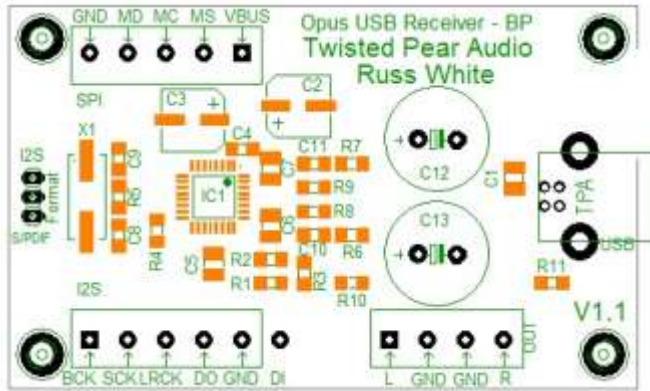

# Adding the Trident regulator

The Trident is a low noise shunt regulator. Trident regulators are the standard and recommended local power regulation for much of the Buffalo III/IIISE's on-board power supply.

There are 3 power supply circuits on the Buffalo III/IIISE board that can be powered by Tridents:

Circuit	Voltage	BIII header	BIIISE header	R4 Resistor value	R8 resistor value (marking)
VDD	1.2V	<a href="#">8</a>	<a href="#">7</a>	10Ω, 1%	100KΩ (104 or 1003)
VDD_XO	3.3V	<a href="#">13</a>	<a href="#">13</a>	20Ω, 1%	1.47KΩ (1471)
DVCC	3.3V	<a href="#">21</a>	<a href="#">21</a>	20Ω, 1%	1.47KΩ (1471)

As the Trident is now the standard power regulator for the Buffalo III-series boards, Twisted Pear Audio offers a combo set of 3 Trident regulators along with the DAC board, with the correct resistors for each of the Buffalo III/IIISE's circuits. For now we assume you will use this option, although it is possible to replace each of the circuits as one sees fit.

There are several versions of the Trident, but not all of them were available for purchase. As of version 3 the Trident comes with a pre-installed R4 surface mount resistor. If you use an older Trident version, you need to install this resistor. In case your sets got mixed up: in the table above is the data you need to sort things out and place them correctly.

Trident regulator data	
Maximum current output	100mA
Input voltage range	5 - 5.5 V (DC)
Recommended input	5 – 5.25 V (DC)
Voltage Tolerance	+/- 1%
Board size (inches)	0.75" x 1.075"
Board size (mm)	19 x 27.3 mm

To install the Trident set, make sure the voltage of the Trident you mount is correct, and the right resistor is soldered on position R4 of the regulator. In the combo set, the bags are marked with the circuit, voltage and packed with the correct resistor for their position. When there is no loose resistor in the package, it should already be in place.

Before soldering the module on the board make sure it is correctly aligned and enough clearance is left for other wiring/items you wish to add. Straight headers are supplied with the board to mount the regulators horizontally above the board.

When delivered the headers are not soldered on the regulator board to allow for alternative methods of connecting them to the DAC board. Fi. You can mount these at the underside of the DAC board if there isn't enough clearance above the DAC board.

## Caution: lower voltage for the Buffalo III-series

When moving from the Buffalo II to a Buffalo III series board, the amount of voltage to the Buffalo III/IIISE board may need to be decreased from the previously recommended voltage of 5.5V to the recommended 5.25V. This change lowers the heat output of the Trident regulators, which have a maximum voltage of 5.5V. On the Buffalo III it also makes sure you supply the correct voltage to attached modules like the S/PDIF-4 Input Board and Sidecar.

Note: When lowering the voltage, on the AVCC module one of the LEDs might get less bright. This is normal behaviour.

# Adding volume control

In previous versions, the Volumite added volume control to the Buffalo-series DAC board. For the Buffalo III-series the Volumite module is no longer needed. Adding volume control is as simple as wiring a suitable potmeter to the DAC board. The Buffalo III/IIISE has on-board volume control, courtesy of the new on-board firmware. When the Buffalo III is combined with the S/PDIF-4 Input Board or S/PDIF 4:1 MUX/Receiver unit it changes the DAC into a flexible DAC/Pre-amplifier configuration. The same applies to the Buffalo IIISE with fi. the OTTO-II or the S/PDIF 4:1 MUX/Receiver board. The on-board volume control is a precise and affordable volume control, it uses the volume control mechanism built into the ES9018.

## Volume control in the DAC

The ES9018 chip has a well designed volume control mechanism built into the chip. The ES9018 has a DSP section that uses 48 bits internally for all important operations. So even with a 32-bit signal there is some precision left for digital attenuation of the signal.

The output volume is set by registers in the DAC, ranging from 0 to -127dB, in 0.5 dB steps. The on-board firmware simply sets the volume registers in the DAC using I2C. So the pot is not in the signal way, it is just a means of measuring the desired attenuation. A change of output volume is done gradually: internally the DAC adjusts the volume in steps of less than 1/64 dB, so the unit smoothly changes it's output signal from the old setting to the new one.

## Volume control in stereo or multi channel mode

Wire the potmeter to the DAC board. Connect the wiper (center), CCW (counter clockwise) and CW (clockwise) pins to the ADC connector (ADC, 15 [on the BIII](#) and [on the BIIISE](#)) of the firmware chip.



Pin on pot	ADC connector
<b>Wiper</b>	PB4
<b>CCW</b>	GND
<b>CW</b>	3.3V

## Volume control when using dual mono mode

Wire the potmeter as described above, but only to the board with the on-board firmware controller.

## Remote control

Adding remote control for the volume has become extremely easy with the Buffalo III/IIISE: just hook up a motorized linear 5-10K pot. It should be no problem to find such a pot, along with the remote control electronics.

Pin on Alps pot	ADC connector
<b>Output</b>	PB4
<b>GND</b>	GND
<b>Input</b>	3.3V

Please note that the on-board volume control will obviously not work if you remove the on-board firmware. So when using external controllers like the AC2, you also need to set the volume if desired.

# Adding the Teleporter

The Teleporter is a small LVDS receiver/transmitter module. LVDS stands for Low Voltage Differential Signaling, which allows high speed signal transmissions over greater distances with a high common mode noise rejection ratio. This means simpler cabling can be used like CAT5 cable, while the signal remains intact even over 100ft cables.

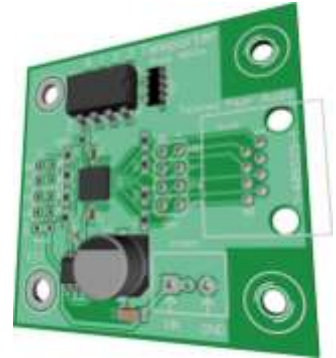

## External interface

The Teleporter is based on the [DS91M040](#) chip and can be used to transmit PCM, I2S and DSD TTL level signals to your DAC, and as such is an ideal addition for the users that wish to add external DSD or I2S connectivity to their DAC. Since there is no shared ground connection, the module provides isolation. It also solves the wire length problems that plague I2S connections.

## For external USB input

The new XMOS based USB module also supports LVDS output, both for it's isolation purpose and high speed transmission. One could use the Teleporter module as an input for the Sidecar module or the Buffalo IIISE, and keep the USB module close to the PC in a separate enclosure. The Teleporter module has been tested with the new module for signals of up to 384Khz, with a 256fs master clock.

## Modding sources

Another use could be for those that wish to mod their (SA)CD player to provide DSD or I2S output. The Teleporter module is small and has an on-board low noise [LT1763](#) regulator, it just requires around 5V input (DC). A suitable power line should be easy to find in most devices.

The Teleporter module has both an RJ-45 connector and a 0.1" header for it's output so if you can't find space to mount an RJ-45 outlet even a small hole will do to run a cable to your DAC. Another Teleporter in your DAC should receive the signal, and translate it back to normal DSD or I2S signals.

## High speed cable connection

The Teleporter module allows one to use extremely high bit rate connections. The part should allow for bitrates of up to 250Mbps, using a 125Mhz clock. This should allow usage of relatively cheap CAT5 and CAT5e cables, since those support clock rates of up to 125Mhz.

To ensure even more headroom one could use CAT6a cables since those are rated at least up to 500Mhz, but it should not be required. HDMI cable could also be used, but it requires one to build an adapter and offers no advantages.

## DIP switch settings

The DIP switch settings for the Teleporter module are very easy. Each of the 4 channels it offers can be configured for either receive or transmit purposes.

Switch	Channel	ON	OFF
1	0	Receive	Transmit
2	1	Receive	Transmit
3	2	Receive	Transmit
4	3	Receive	Transmit

## Proposed default connection scheme

Since there is no well defined standard for I2S connections, Twisted Pear Audio proposes a default connection scheme to ensure compatibility between various DACs and external sources.

The ideal order for PCM into Buffalo II/III/IIISE would be:

Channel	Usage
0	Bit clock
1	Word clock
2	Data
3	Optional master clock (typically not used)

For DSD it would be:

Channel	Usage
0	Bit clock
1	Data left
2	Data right
3	Unused for asynchronous stereo - but could possibly be master clock

## RJ45 connection scheme

The mapping of LVDS channels to the RJ45 connector is this:

RJ-45 pin	LVDS Signal
1	B0
2	A0
3	B2
4	B1
5	A1
6	A2
7	B3
8	A3

## Teleporter specification

Item	Value
<b>Max. Input signal</b>	250 Mbps (125Mhz), tested up to 100Mhz
<b>Max. Input signal voltage</b>	3.3V
<b>Input voltage</b>	5 ~ 8V DC, 5 - 6V DC recommended
<b>Power usage</b>	± 150 mA max. (depends on frequencies and number of channels in use)
<b>Max. cable length</b>	100 ft (30 metres)
<b>Pulse skew</b>	55 ps
<b>Propagation delay</b>	3 ns (same on all 4 channels)
<b>Channel to channel skew</b>	60 ps
<b>Dimensions</b>	1.75" x 1.7"
<b>Dimensions (mm)</b>	44.5mm x 43.2mm

# Adding the S/PDIF 4:1 MUX/Receiver Module

The S/PDIF 4:1 MUX/Receiver is based on the Cirrus Logic [CS8416](#) S/PDIF receiver chip. It allows you to switch between 4 different transformer-coupled S/PDIF inputs, one of which may be AES/EBU. The signal is sent to a transformer coupled S/PDIF output and I2S.

The S/PDIF 4:1 MUX/Receiver can be used with all Buffalo-series boards. On the Buffalo III however, it's function can be added at a lower cost with the newer [S/PDIF-4 Input Board](#).

The recommended way of connecting the S/PDIF 4:1 MUX/Receiver is I2S, with lines that are kept as short as possible. See below how to connect the MUX module to the DAC board.

MUX unit (and other I2S sources)	Buffalo III/IIISE DAC board
<b>MCK</b>	Not connected
<b>GND</b>	GND
<b>BCK (Bit clock)</b>	DCK
<b>LRCK (Word clock)</b>	D1
<b>DOUT (Data)</b>	D2
<b>SPDIF -</b>	Not connected
<b>SPDIF +</b>	Not connected

## 4 S/PDIF or 3 S/PDIF and 1 AES/EBU

Input number 4 of the S/PDIF 4:1 MUX/Receiver can be either S/PDIF or AES/EBU. In the standard configuration the input is configured for AES/EBU. By placing a jumper over R7 the input is configured for normal S/PDIF usage.

## Switching inputs

The MUX module can be operated using an microcontroller like for instance an Arduino board or the AC2. But it is also possible to use the included 4-position selection switch or the 2-bit Selector board.

Switching is done with the SELECT connector:

Pin	Usage
<b>VD</b>	3.3V connector
<b>0</b>	Terminal 0
<b>1</b>	Terminal 1
<b>G</b>	Ground connector

By setting the 0 and 1 terminals or pulling them to ground the inputs are selected:

Input	Terminal 0	Terminal 1
<b>1</b>	Low (GND)	Low (GND)
<b>2</b>	High (3.3V)	Low (GND)
<b>3</b>	Low (GND)	High (3.3V)
<b>4 (AES/EBU)</b>	High (3.3V)	High (3.3V)

## S/PDIF 4:1 MUX/Receiver DIP switch settings

The onboard DIP switch SW1 controls the settings of the S/PDIF 4:1 MUX/Receiver.

SW1	Setting	+	-
1	Phase detector update rate	High (32-108KHz input)	Normal (32-192KHz input)
2	Recovered master clock frequency	128*Fs (>48KHz input)	256*Fs (Only use with 32-48KHz input)
3	Automatic de-emphasis filter	Enabled	Disabled
4	Receiver error indicator	RERR	NVERR

### Phase detector update rate

The phase detector update rate should only be set to “High” with input signals ranging from 32 to 108KHz. If the phase detector update rate is set to “High” outside of this range, unlocks may occur.

### Recovered master clock frequency

This setting sets the output recovered master clock frequency. The 256\*Fs setting is typically used for input signals ranging from 32KHz to 48KHz, while the 128\*Fs is typically used for input signals of 48KHz and above.

The Buffalo-series DAC boards do not use the recovered master clock, and the COD and Opus DAC boards will work fine with signals up to 192KHz with the recovered master clock frequency set to 128\*Fs.

### Receiver error indicator

Setting	Meaning
<b>RERR</b>	The previous audio sample is held and passed to the serial audio output port if the validity bit is high, or a parity, bi-phase, confidence or PLL lock error occurs during the current sample
<b>NVERR</b>	The previous audio sample is held and passed to the serial audio output port if a parity, bi-phase, confidence or PLL lock error occurs during the current sample

Note: After changing the settings, a power cycle or reset of the receiver is required.

## S/PDIF 4:1 MUX/Receiver specification

Item	Value
<b>Input voltage</b>	5-12V DC
<b>Power usage</b>	± 30mA (@44.1KHz) to ± 60mA (@192KHz)
<b>Dimensions</b>	3.3" x 2"
<b>Dimensions (mm)</b>	83.8 x 50.8 mm

# Lay-out of the S/PDIF 4:1 MUX/Receiver

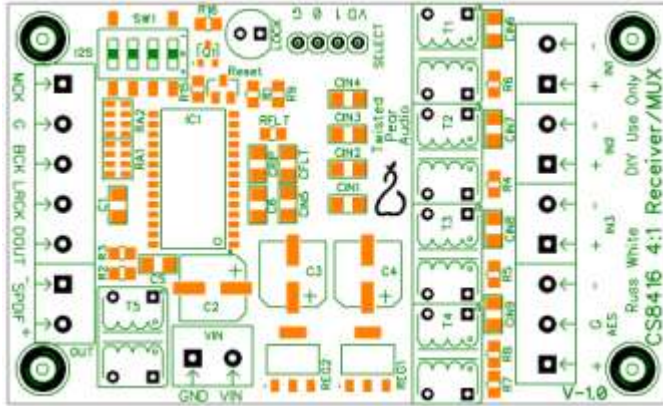

# The input selection switch: the 2-bit Selector board

The 2-bit Selector board can be used as a 4 position switch. It sets the LSB (Least Significant Bit) and MSB (Most Significant Bit) for modules like the S/PDIF 4:1 MUX/Receiver, OTTO-4 or the on-board firmware controller of the Buffalo III.

To switch between the inputs, the 2-bit Selector board uses a 4 position rotary switch. It features 4 LEDs to indicate the current selection. If you wish to use the LEDs that indicate the input in use, connect 3.3V to the VDD pin on the switch module. Use the included 4-pin header to connect the following:

Connection	Switch board
VDD	2
GND	4
Low bit	6
High bit	8

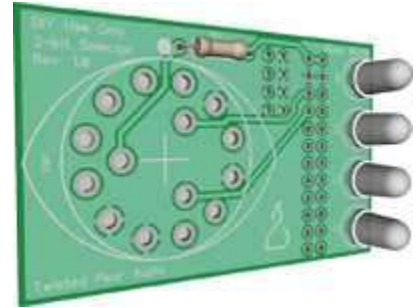

On the switch module, the 4 pins ([on switch module: EXT\\_IO, 6](#)) you need to use are conveniently marked with a rectangle on the rear of the board. Also four 2-pin connectors are located at the rear of the board ([on switch module: LEDs, 5](#)) in a convenient 0.1"x0.1" pitch grid, to simplify the connection to off-board LEDs. The individual connectors are numbered from 1 to 4 to indicate which connector corresponds to which LED.

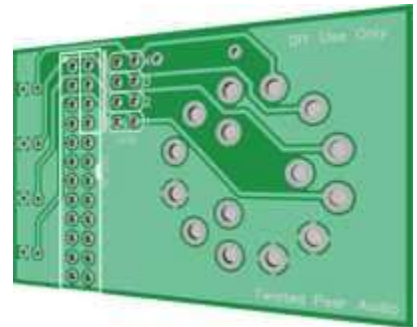

Please note the EXT\_IO and LED connectors should be mounted on the rear of the rotary switch module board, as otherwise one would be unable to easily mount the switch module in a chassis. The onboard LEDs on the other hand can be mounted on the front of the board, to allow them to be mounted right next to the source selection knob in the front panel of your chassis.

## Lay-out of Switch Module

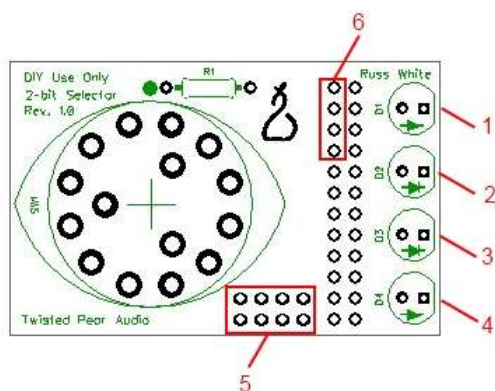

Marked	Description
1 D1	Connector for LED of input 1
2 D2	Connector for LED of input 2
3 D3	Connector for LED of input 3
4 D4	Connector for LED of input 4
5 LEDs (rear), 1 to 4	Connector block for off-board LEDs
6 EXT IO (rear)	(4-pin) connector to DAC board

# Adding the Metronome

The Metronome is a reclocking module for PCM (I2S) signals. It consists of a Texas Instruments [SRC4192](#) Asynchronous Sample Rate Converter chip (ASRC) and a [Crystek high-precision oscillator \(24.576MHz, 25ppm\)](#).

The ES9018 chip on the Buffalo III-series DAC board like most modern DAC chips requires 64fs bit clock I2S input. If the clock of your source (fi. 48fs CDPPro transport) is different, the DAC will not be able to lock on the signal. The Metronome can be used to reclock the signal to make it compatible with the ES9018. The Metronome is designed for input signals of up to 212KHz and outputs signals at sample rates of 48, 96 or 192KHz.



The output rate of the Metronome is set by the MODE switches, set these according to your own preference:

Output	MODE0	MODE1	MODE2
48Khz (512fs)	-	+	-
96Khz (256fs)	+	+	-
192Khz (128fs)	+	-	-

The 24-bit I2S configuration is as follows:

Switch	Setting
OWL0	-
OWL1	-
OFMT1	-
OFMT0	+
IFMT2	-
IFMT1	-
IFMT0	+
BYPASS	-
LGRP	-
Unused switches	In the center (0) position

Wire the source to the PCMIN connector, and connect the DAC or Sidecar board to the PCMOUT connector.

Marking	Usage
BCK	Bit clock
SCK	System or reference clock. Note: normally not used
LRC	Word clock
D	Data
G	Digital ground

Note: although the Metronome can reclock the signal to remove jitter, it is NOT recommended to use it for this purpose in combination with the ES9018 chip. The ES9018 has a very good jitter removal mechanism, and uses an excellent clock module for this purpose.

## Metronome Specification

Item	Value
Max. Input signal	212 KHz
Output signal	48KHz, 96KHz or 192KHz
Input voltage	4.5 ~ 7.5V DC, 5.25V DC recommended
Power usage	<100mA typically
Dimensions	3.3" x 2"
Dimensions (mm)	83.8 x 50.8 mm

## Lay-out of the Metronome

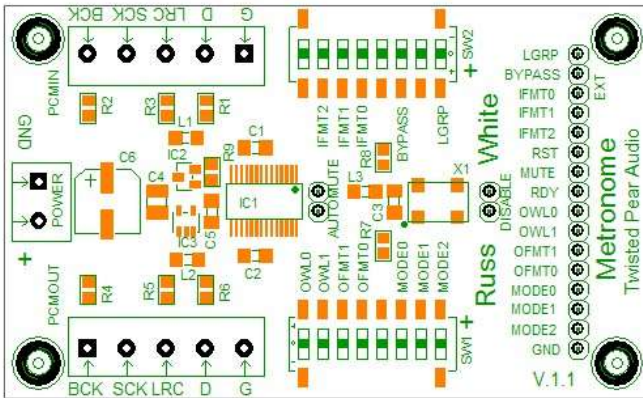

# Multiple I2S/DSD connections: OTTO-II

The OTTO-II module allows multiple connections to the DAC board. This module makes it possible to switch between two S/PDIF, I2S (PCM), DSD or even other types of inputs.

The module provides a simple switch of up to 4 channels, without circuit bounce. It has been tested with signals up to 100Mhz. You switch between the sets B1 and B2 by connecting S to either VCC or pulling it to ground (GND). The common pins are on connector A. Switching can be done with a simple switch or by a microcontroller. All external connections to the board can be made with either terminal blocks, 0.1" headers or with uFL coax connectors.

Note: uFL connectors are only available on the V1.1 board.

## Switching OTTO-II with a simple switch

- The entire OTTO-II module is enabled by connecting OE to GND. Place a jumper on OE to GND.
- Connect S to VCC using a pull-up resistor of 4.7-10K  $\Omega$ . A suggestion for this resistor can be found in the [extended bill of materials](#).
- Connect S to one pole on the switch and connect the other pole of the switch to GND.

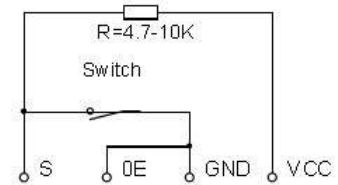

By closing the switch, S is connected to ground. Connector A will be switched to B1. When the switch is open A will be switched to B2.

Input/output	S connected to GND	S connected to VCC
1A	1B1	1B2
2A	2B1	2B2
3A	3B1	3B2
4A	4B1	4B2

Note: the signals that are switched should be less or equal than VCC.

## OTTO-II specification

Item	Value
Max. Input signal	100 MHz
Max. delay through switch	<0.25ns
Max. current through any channel	50mA
Input voltage	4 ~ 5.5V DC, 5 - 5.5V DC recommended
Power usage	<10ma
Dimensions	2.325" x 1.5"
Dimensions (mm)	59.1 x 38.1mm

## Lay-out of the OTTO-II

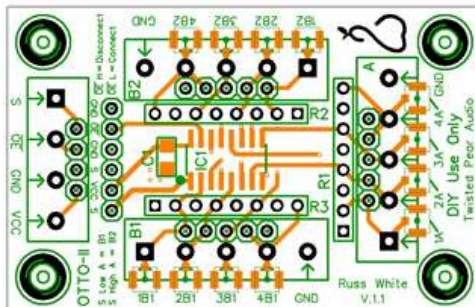

# Adding optical input: the TOSLINK Optical Input Module

For TOSLINK (the optical version of S/PDIF) you need a TOSLINK Optical Input Module Kit. This kit offers TTL level output so you could connect it directly to the Buffalo III/IIISE board, but it can also be connected to one of the S/PDIF-4 Input Board's inputs.



When connecting the Toslink module to the [S/PDIF-4 Input Board](#) a suitable voltage divider is required to bring the signal down to consumer level S/PDIF. On new versions of the Toslink module, the resistors RS and RP act as a voltage divider. See the table below:

Toslink output	RS	RP
TTL level	0Ω	Do NOT use
Consumer level	270Ω	75Ω

If you have an old version, these resistors can be connected from the OUT and G terminals of the Toslink module to the + and – terminals of the S/PDIF-4 Input Board as shown in the diagram.

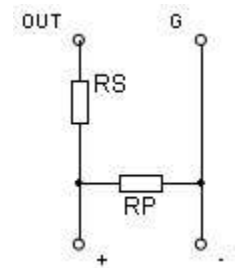

The TOSLINK module is limited in resolution to 24-bit / 96KHz and it requires 5-12V DC input.

Tip: when the only required inputs for your Buffalo IIISE are TOSLINK and Coax, build the TOSLINK module with TTL level output. Connect the Coax signal to the S/PDIF/GND pins, and the TOSLINK module to the D1/GND pins.

# Advanced features

## Using external I2C controllers

The onboard firmware controller (IC8, 14 [on the BIII](#) and [on the BIII SE](#)) is an I2C bus master. Since only one master is allowed on this bus, remove the onboard firmware controller when using an external controller on the I2C bus (AC2 for example).

The I2C header (I2C, 17 [on the BIII](#) and [on the BIII SE](#)) is used to communicate with the DAC from a controller such as the AC2. It includes a 3.3V supply voltage for modules that can use it. If using the 3.3V supply do not exceed 75ma load.

When using dual mono mode, the left and right boards get different I2C addresses:

Mode	Address
<b>Stereo</b>	0x90 (144 decimal)
<b>Mono – Left</b>	0x90 (144 decimal)
<b>Mono – Right</b>	0x92 (146 decimal)

When using a controller like fi. the AC1 or AC2 in dual mono mode, remember to set the volume registers on both boards using I2C commands.

## Reset

The reset header (RESET, [27 on the BIII](#) and [24 on the BIII SE](#)) is used to reset the DAC if necessary. This is not normally needed even when changing registers.

# Powering it all

In the Twisted Pear Audio module range there are 2 main types of modules when one looks at the power requirements:

1. Modules that require approx. 5.25V DC input
2. Modules that require approx. 15V bipolar DC input (meaning it uses 3 voltages: -15V, 0V and 15V)

This is an overview of the most common modules used, with their power requirement:

Module	Normal (5.25V DC)	Bipolar (15V DC)	Current requirement
<b>Ballsie Lite</b>		√	
<b>Buffalo III/IIISE DAC Board</b>	√		~440mA
<b>IVY3</b>		√	90~150mA
<b>Legato</b>		√	~350mA
<b>Metronome</b>	√		<100mA
<b>OTTO-II</b>	√		<10mA
<b>Sidecar</b>	√		~65mA
<b>Single S/PDIF Level Converter</b>	√		~10mA
<b>S/PDIF-4 Input Board</b>	√		20~30mA
<b>Teleporter</b>	√		~150mA
<b>TOSLINK Optical Input Module</b>	√		
<b>Ventus EZ</b>		√	

Twisted Pear Audio offers power supplies for each type of module:

Power supply	Normal (5.25V DC)	Bi-polar (15V DC)	Type	Remark
<b>Placid</b>	√		Shunt	Replaced by Placid HD series
<b>Placid BP</b>		√	Shunt	Replaced by Placid HD series
<b>Placid HD</b>	√		Shunt	
<b>Placid HD BP</b>		√	Shunt	
<b>LCDPS</b>	√		Series: CLRC	Dual circuit: offers 2 outputs
<b>LCBPS</b>		√	Series: CRC	

## Shunt power supply

The Placid and Placid HD series of power supplies are shunt regulators. This means the power supply delivers more power (referred to as CCS current) than is required at any time. The excess power supplied is shunted (shunt current) and usually transformed into heat. As one might understand this is not the most efficient use of power, but it does offer a very clear advantage: the output of shunt regulators usually has extremely low amounts of noise. This makes it a favorite choice for audio applications.

Shunt power supplies by their very nature require sufficient cooling capacity to get rid of the heat. For this reason the Placid series already uses bigger heatsinks than the LCDPS power supply. High temperatures are normal for this kind of power supply. Action is only required if the temperature levels of your Placid-series heatsinks exceed 80° Celcius (176 F). In such a case you should consider the following options:

### Lower power usage, or distribute the load across multiple power supplies

Always check your amount of shunt current if you see high temperatures. As most of the modules present a fairly constant load, 50mA of shunt current should be sufficient in most cases. Check the manual of your specific Placid power supply on how to adjust the CCS and shunt current. Also check the power usage of individual modules: if the usage is way too high you might have a problem on the module involved.

If you can't find a way to save power or if the other options are impossible as they do not deliver enough headroom for the current required you should distribute the load across multiple power supplies. For instance: in case of a dual mono Buffalo III setup, there is no way both of the DAC boards can be powered from a single Placid or even Placid HD power supply. In such a case two Placid HD power supplies should be used: one for left, and one for the right DAC board.

#### Increase cooling capacity by using bigger heatsinks

This can only be done in a small amount of cases. Of course the first requirement is that there should be enough room in the enclosure for taller heatsinks. Going from the standard 1.5" to 2" heatsinks should give you around 9-10° Celcius of extra headroom. A suggested part can be found in the [extended bill of materials](#). Even bigger versions than 2" do exist, but most of the time those are special order items plus they would rarely fit in a normal enclosure.

Another option would be to mount the parts to the chassis instead of using a heatsink. This is possible only when the chassis is a good thermal conductor like aluminium. There is no need for electric isolation, as the parts that Twisted Pear Audio provides are already isolated. Invert the parts that are normally attached to heatsinks so they are mounted below the board, and can be mounted to the chassis.

#### Increase cooling capacity by increasing air flow

Instead of using natural convection for cooling, one could use a fan to increase the cooling capacity. The disadvantage is clear: the fan generates noise, so this should only be done if the enclosure you want to use is too small to use any of the other methods.

### Old versions of the Placid and LCDPS

Please beware that the original Placid power supply (the non-HD version) was only intended for loads of up to 400-450mA. If the load is bigger, like that of a Buffalo III with Sidecar and S/PDIF-4 Input Board the power supply loses some of its excellent low noise characteristics.

Using a LCDPS is a more sensible configuration in this case, especially in a dual mono setup since a single LCDPS can power two circuits. Since the Trident modules are shunt regulators with a high noise rejection, one doesn't need to use a Placid shunt regulated power supply to obtain good results.

Note: the newer Placid HD version is an even more stable and capable solution, but one does need two of those to power a dual mono setup.

#### Older version of LCDPS

The power draw of a Buffalo III board with a full Trident combo set installed is around 440mA. If one is using an old style LCDPS power supply, replace the resistors R1 to R4 on the LCDPS with 1Ω versions, or simply put jumpers on these positions to enable it to deliver more than 400mA. Newer versions of the LCDPS ship with suitable resistors (2.7Ω, 3W) for higher currents and shouldn't need to be modified.

#### Older version of Placid

If you already have a Placid it is possible to use it, but beware that the amount of power supplied to the DAC board needs to be changed. See the Placid manual about adjusting the shunt current. Depending on the situation, one may have to increase the size of the heatsinks on the Placid to counter the increased heat dissipation. A suggested part can be found in the [extended bill of materials](#).

## Connecting the transformers

The 9V transformer is connected to the 5.25V power supply, being either a Placid (HD) or LCDPS. The 15V transformer is connected to the 15V bipolar power supply, either a Placid (HD) BP or LCBPS. The colors used are described below:

Transformer	Load	Primary 1	Primary 2	Secondary 1	Secondary 2
9V	15VA	Blue, Grey	Violet, Brown	Black, Red	Orange, Yellow
15V	30VA	Blue, Grey	Violet, Brown	Black, Red	Orange, Yellow

### Connecting the primary wires

For 115V use, connect the primary windings in parallel by connecting both Blue and Violet to the neutral wire and connecting both Grey and Brown to the hot wire.

For 230V use, connect the primary windings in series by connecting Grey to Violet, connect Blue to the neutral wire and connect Brown to the hot wire.

### Connecting the secondary wires

When connecting the Placid or Placid HD, one could connect one of the secondary sets (Black, Red) to the power supply and use the second set (Orange, Yellow) to another power supply. Beware though that this does mean only half of the power (7.5VA) is available for the power supply, and the other half goes to the other power supply. Also there is no complete galvanic isolation between those two power supplies. The other option is to run parallel, fi. combine Black and Orange, and Red and Yellow to the respective inputs on the power supply.

When connecting the LCDPS, one should connect one of the secondary sets (Black, Red) to the first half of the power supply and use the second set (Orange, Yellow) to connect to the other half of the power supply.

When connecting the Placid HD BP or LCBPS, one should connect one of the secondary sets (Black, Red) to the negative half of the power supply and use the second set (Orange, Yellow) to connect to the positive half of the power supply.

## Common problems and solutions

### Voltages sag

This is a fairly common error on all of the Placid power supplies. If there is an insufficient amount of CCS current, the voltage will sag as the power supply runs out of current to shunt. Increase the amount of CCS current to solve this issue.

### Increase power

If the power range on the Placid does not allow you to go to the desired power level, you could try the following, depending on the power supply used:

Power supply	Raise power by
Placid V2.0	Reduce R6 to 4.7Ω, or even short it
Placid V2.0.1	Reduce R5 to 4.7Ω, or even short it
LCDPS (old version)	Reduce R1 to R4 to 1Ω, or even short it
Placid HD	No modification needed, but needs adequate heatsinks for loads above 500mA

Tip: For IVY III owners, shorting is the easiest way to raise the power as several jumpers (0Ω) are included with the IVY III kit and in most cases, those jumpers will remain unused.

### **Beware of drift**

When using a Placid or Placid HD take in account that a shunt PSU like the Placid may drift a bit in voltage during warm up. Usually the output voltage will be slightly higher when the PSU is still cold. The typical change may be a few tenths of a volt. For the Buffalo III, the most sensible thing to do is make fine adjustments when the Placid or Placid HD is warm. That way the voltage at startup will be just a little higher at startup, but it should still be low enough to not cause any damage.

## Appendix: Pin lay-out of the external I/O connector

VDD	GND	B0	B1	B2	B3	B4	B5	B6	B7	INTB	SCL
2	4	6	8	10	12	14	16	18	20	22	24
1	3	5	7	9	11	13	15	17	19	21	23
VDD	GND	A0	A1	A2	A3	A4	A5	A6	A7	INTA	SDA

Pin	Description
1	Microcontrollers VDD power supply (3.3V)
2	Microcontrollers VDD power supply (3.3V)
3	Ground connector
4	Ground connector
5	A0
6	B0
7	A1
8	B1
9	A2
10	B2
11	A3
12	B3
13	A4
14	B4
15	A5
16	B5
17	A6
18	B6
19	A7
20	B7
21	INTA
22	INTB
23	SDA (I2C)
24	SCL (I2C)

When using the EXT\_IO connector please beware that OFF means the switch is open and ON means the switch is closed.

Beware: the pins 5 to 20 duplicate the switches SW1 (A0 – A7) and SW2 (B0 – B7). Depending on the board/firmware combination, these switches may control different functions.

## Appendix: Bill of materials for stereo mode DAC

Description	Amount	Notes
<b>Buffalo II/III DAC board with Trident regulator combo set</b>	1	
<b>I/V output stage: IVY III or Legato 3.1</b>	1	For the Legato 3.1, use the version with output buffer unless you are certain you don't need a buffer.
<b>Placid HD power supply</b>	1	Used for powering the DAC board and other digital modules.
<b>Placid HD BP power supply</b>	1	Used for powering the I/V stage. Multiple units can be connected to a single IVY or Legato output stage
<b>Transformer 9V</b>	1	15VA transformer for the Placid HD power supply
<b>Transformer 15V</b>	1	30VA transformer for the Placid HD BP power supply, dual secondary windings required.

Other items required:

- Enclosure
- Connectors for input/output and power
- Internal wiring

Twisted Pear Audio provides several other useful items for your project:

Description	Notes
<b>USB DAC/Receiver</b>	Basic USB receiver. Supports a maximum of 16 bits / 48KHz.
<b>TOSLINK Optical Input Module Kit</b>	TOSLINK to S/PDIF connection
<b>Teleporter</b>	LVDS transmitter/receiver module for longer signal lines. Common usage for this module: create a I2S/DSD input for your DAC.
<b>Metronome</b>	ASRC module for reclocking PCM (I2S) signals if the source is incompatible with the ES9018.
<b>OTTO-II</b>	Switch between two I2S/DSD inputs

## Appendix: Bill of materials for dual mono mode DAC

Description	Amount	Notes
<b>Buffalo IIISE DAC board with Trident regulator combo set</b>	2	
<b>I/V output stage: IVY III or Legato 3.1</b>	2	For the Legato 3.1, use the version with output buffer unless you are certain you don't need a buffer.
<b>LCDPS or Placid HD power supply</b>	1 or 2	Used for powering the DAC board and other digital modules. The LCDPS offers 2 separate circuits. If using the LCDPS only one 9V transformer is required.
<b>Placid HD BP power supply</b>	2	Used for powering the I/V stage. Multiple units can be connected to a single IVY or Legato output stage
<b>Transformer 9V</b>	1 or 2	15VA transformer for the Placid HD power supply
<b>Transformer 15V</b>	2	30VA transformer for the Placid HD BP power supply, dual secondary windings required. Feed each Placid HD BP power supply with a separate 15V transformer for maximum separation.
<b>Ballsie Lite or Ventus EZ (2-channel kit)</b>	1	Required only if you want single ended output.

Other items required:

- Enclosure
- Connectors for input/output and power
- Internal wiring

Twisted Pear Audio provides several other useful items for your project:

Description	Notes
<b>USB DAC/Receiver</b>	Basic USB receiver. Supports a maximum of 16 bits / 48KHz.
<b>TOSLINK Optical Input Module Kit</b>	TOSLINK to S/PDIF connection
<b>Teleporter</b>	LVDS transmitter/receiver module for longer signal lines. Common usage for this module: create a I2S/DSD input for your DAC.
<b>Metronome</b>	ASRC module for reclocking PCM (I2S) signals if the source is incompatible with the ES9018.
<b>OTTO-II</b>	Switch between two I2S/DSD inputs

# Appendix: Bill of materials for multi channel DAC

Description	Amount	Notes
<b>Buffalo III DAC board with Trident regulator combo set</b>	1	
<b>I/V output stage: IVY III</b>	4	IVY III works a little better when only 1 DAC channel feeds it instead of the normal 4 channels.
<b>Placid HD power supply</b>	1	Used for powering the DAC board and other digital modules.
<b>Placid HD BP power supply</b>	1	Used for powering the I/V stage. The HD version is powerful enough to feed 4 IVY III's. Do not try this with the older versions. If required multiple Placid HD BP's can share the same 15V transformer, just keep the wiring to all PSUs identical.
<b>Transformer 9V</b>	1	15VA transformer for the Placid HD power supply
<b>Transformer 15V</b>	1	30VA transformer for the Placid HD BP power supply, dual secondary windings required.

Other items required:

- Enclosure
- Connectors for input/output and power
- Internal wiring

Twisted Pear Audio provides other useful items for your project:

Description	Notes
<b>Teleporter</b>	LVDS transmitter/receiver module for longer signal lines. Common usage for this module: create a I2S/DSD input for your DAC.
<b>Metronome</b>	ASRC module for reclocking PCM (I2S) signals if the source is incompatible with the ES9018.
<b>OTTO-II</b>	Switch between two I2S/DSD inputs

## Appendix: Extended bill of materials

For people who do not want to waste time searching for special parts, a list has been made of items one could use. Please note these are suggestions: one should check if these meet the local regulations, plus your own demands. These items are carefully selected, but not always tested for fitness for use.

Description	No	Mfg#	DigiKey#	Mouser#
<b>IEC connector with filter, fuse and on/off button</b>	1	DD12.2121.111	486-1291-ND	693-DD12.2121.111
<b>Fuse holder for IEC connector</b>	1	4301.1403	486-1274-ND	693-4301.1403
<b>Fuse</b>	2	5SF 2-R	507-1228-ND	
<b>Fast-on connector for IEC</b>	3	735159	735159-ND	571-735159-1
<b>XLR male chassis connector (for balanced outputs)</b>	2	NC3MP-BAG		568-NC3MP-BAG
<b>XLR female chassis connector (for AES balanced input)</b>	1 to 4	NC3FP-BAG-1		568-NC3FP-BAG-1
<b>RCA chassis connector (single ended outputs)</b>	2	WBT-0210 Cu or Ag		
<b>BNC chassis connector (Coax, 75 ohm)</b>	1 to 4	31-10-75	ARF1121-ND	523-31-10-75
<b>54.9Ω resistor for high voltage AES/EBU option</b>	2		CMF54.9HFCT-ND	71-RN60D54R9F
<b>75Ω resistor for voltage divider on Toslink module</b>	1		PPC75.0YCT-ND	71-CCF5575R0FKE36
<b>270Ω resistor for voltage divider on Toslink module</b>	1		S270CACT-ND	71-RN60D2700F
<b>1KΩ resistor for triggering Sidecar with input switch</b>	1		CF14JT1K00CT-ND	71-RN60D1001F/R
<b>10K resistor for switching OTTO-II</b>	1		CF18JT10K0CT-ND	299-10K-RC
<b>Taller heatsink (For high loads on Placid HD-series)</b>	2	637-20ABP	345-1030-ND	567-637-20ABP

The resistors in the above table have been selected for their availability and price. In most cases any decent resistor of the correct value will do.

For European consumers, one of the most common choices for DIY projects is the Hifi2000 enclosure. The selected enclosure matches the Neutrik XLR connectors listed above in colour (black), and is big enough to build a dual mono setup with multiple Placids (+BPs) and their transformers, with room to spare for an AC2 controller, display, etc. The big knob is an ideal choice for use with the on-board volume control, while the smaller one is very suitable for the input switch of the S/PDIF-4 Input Board.

Description	Mfg#	Available from
<b>Knob, 29mm diameter</b>	1MN30N	<a href="http://www.modushop.biz">http://www.modushop.biz</a>
<b>Knob, 39mm diameter</b>	1MN40N	<a href="http://www.modushop.biz">http://www.modushop.biz</a>
<b>Enclosure: 2U, 19"x350mm with 10mm front and 3mm covers</b>	1NSLA02350N	<a href="http://www.modushop.biz">http://www.modushop.biz</a>

## Molex Grid connectors

The following items are optional. You can use them to provide a more professional finish for the board by making all connections with a modular connector. Simply populate the positions you need for your connections in the connector housing. As with all crimp connectors: use the right crimping tool, if you use a size too tall or even use simple pliers the connection may be erratic.

Note: The Molex Grid connectors allow for thicker wire and are a more flexible approach. For people that want to build a dual mono setup the higher wire capacity may be of value.

Description	Molex#	DigiKey#	Mouser#	Typical usage
<b>Female connector</b>	16-02-0104	WM2564-ND	538-16-02-0104	Insert into housing, use 22-24 AWG wire
<b>1x2 pin housing</b>	50-57-9002	WM2800-ND	538-50-57-9002	For connecting off-board LEDs
<b>1x3 pin housing</b>	50-57-9003	WM2801-ND	538-50-57-9003	For output header in multi-channel configurations
<b>1x4 pin housing</b>	50-57-9004	WM2802-ND	538-50-57-9004	For I2C connection
<b>2x10 pin housing</b>	22-55-2201	WM2527-ND	538-22-55-2201	For input connector
<b>2x12 pin housing</b>	22-55-2241	WM2529-ND	538-22-55-2241	For External I/O connector
<b>2x50 pin header</b>	70280-0458	WM268100-ND	538-70280-0458	Cut to length as needed
<b>1x36 pin header</b>	22-28-4363	WM6536-ND	538-22-28-4363	Cut to length as needed for address, I2C and output headers
<b>Crimp tool</b>	63811-1000	WM9999-ND	538-63811-1000	
<b>Crimp tool</b>	64016-0201	WM17552-ND	538-64016-0201	Alternative for 63811-1000: Crimp tool with ratchet

## Board to board connectors

And for those that want to connect the Sidecar module using board-to-board connectors instead of bandcable:

Description	Manufacturer#	DigiKey#	Mouser#
<b>2x10 pin header</b>	70246-2004	WM3479-ND	538-70246-2004
<b>2x10 pin connector</b>	15-44-5820	WM2592-ND	538-15-44-5820

## Replacement female header

This connector sometimes gets damaged during re-soldering. It is used for mounting the AVCC (4-pin) and I/V stage and Trident regulators (3-pin).

Description	Manufacturer#	DigiKey#	Mouser#
<b>1x3-pin connector female</b>	Tyco 5-534237-1	A32904-ND	571-5-534237-1
<b>1x4-pin connector female</b>	Tyco 5-534237-2	A32905-ND	571-5-534237-2

## Replacement header for stacking I/V stages

These are extra long headers for stacking the DAC on top of your I/V stage (Legato or IVY3). Cut these to the amount of pins required (normally 3-pins).

Description	Manufacturer#	DigiKey#	Mouser#
<b>1x36-pin header</b>	3M 929647-04-36-I	929647-04-36-ND	517-647-04-36

## Replacement IDC connectors and headers

The standard method of connecting the Buffalo III modules is bandcable with IDC connectors. Suitable connectors are shipped with the board and modules. Cut away the wires in the bandcable you do not use, and split the cable if required. If a header or connector gets damaged, or if you like to order spares: these are suitable replacement parts.

For Molex:

Description	Molex#	DigiKey#	Mouser#	Typical usage
<b>2x10-pin connector</b>	1658623-4	ASC20B-ND	571-1658623-4	Digital Input connector
<b>2x10-pin header</b>	5104338-4	A33176-ND	571-5104338-4	Digital Input connector
<b>20-pin Strain relief</b>	499252-2	ASSR20-ND	571-499252-2	Digital Input connector
<b>2x12-pin connector</b>	1658623-5	ASC24B-ND	571-1658623-5	For External I/O connector
<b>2x12-pin header</b>	5104338-5	A97492-ND	571-5104338-5	For External I/O connector
<b>24-pin Strain relief</b>	1-499252-0	ASSR24-ND	571-14992520	For External I/O connector

Or from 3M:

Description	3M#	DigiKey#	Mouser#	Typical usage
<b>2x10-pin connector</b>	89120-0103	-	517-8920	Digital Input connector
<b>2x10-pin header</b>	N2520-6002RB	MHC20K-ND	517-N2520-6002RB	Digital Input connector
<b>20-pin Strain relief</b>	3448-89120	MKSR20-ND	517-3448-89120	Digital Input connector
<b>2x12-pin connector</b>	89124-0103	-	517-8924	For External I/O connector
<b>2x12-pin header</b>	N2524-6002RB	MHC24K-ND	517-N2524-6002RB	For External I/O connector
<b>24-pin Strain relief</b>	3448-89124	MKSR24-ND	517-3448-89124	For External I/O connector

And of course some cable:

Description	3M#	DigiKey#	Mouser#	Typical usage
<b>20-wire cable</b>	3365/20 300SF	MC20G- <length>-ND	517-3365/20FT	<length> is the length in feet, various choices ranging from 5 to 300ft.
<b>24-wire cable</b>	3365/24 300SF	MC24G- <length>-ND	Only in 100 or 300ft	<length> is the length in feet, various choices ranging from 5 to 300ft.

Notes:

- 20-wire cable can be ordered from Twisted Pear Audio, see the parts bin on the site.
- 24-wire cable normally isn't needed as one could just use 4 wires to connect the 2-bit rotary switch module to the DAC board.

## Appendix: References

Reference	Link
<b>Avel Lindberg Y23 transformer datasheet</b>	<a href="http://www.avellindberg.com/pdf/avel_y23_range.pdf">http://www.avellindberg.com/pdf/avel_y23_range.pdf</a>
<b>Cirrus Logic CS8416 S/PDIF receiver</b>	<a href="http://www.cirrus.com/en/pubs/proDatasheet/CS8416_F3.pdf">http://www.cirrus.com/en/pubs/proDatasheet/CS8416_F3.pdf</a>
<b>Crystek C33xx clock module</b>	<a href="http://www.crystek.com/crystal/spec-sheets/clock/C33xx.pdf">http://www.crystek.com/crystal/spec-sheets/clock/C33xx.pdf</a>
<b>DIY audio Buffalo II thread</b>	<a href="http://www.diyaudio.com/forums/twisted-pear/160782-buffalo-ii.html">http://www.diyaudio.com/forums/twisted-pear/160782-buffalo-ii.html</a>
<b>DIY audio Buffalo III thread</b>	<a href="http://www.diyaudio.com/forums/twisted-pear/188941-buffalo-iii-flexibility-without-compromise.html">http://www.diyaudio.com/forums/twisted-pear/188941-buffalo-iii-flexibility-without-compromise.html</a>
<b>ESS 9018 product brief</b>	<a href="http://www.esstech.com/products/digitalaudio/Sabre%20PF%20080221.pdf">http://www.esstech.com/products/digitalaudio/Sabre%20PF%20080221.pdf</a>
<b>ESS Sabre family whitepaper</b>	<a href="http://www.esstech.com/PDF/sabrewp.pdf">http://www.esstech.com/PDF/sabrewp.pdf</a>
<b>Linear Technology LT1763 datasheet</b>	<a href="http://www.linear.com/docs/Datasheet/1763fg.pdf">http://www.linear.com/docs/Datasheet/1763fg.pdf</a>
<b>Maxim MAX9201ESE+ datasheet</b>	<a href="http://datasheets.maxim-ic.com/en/ds/MAX9201-MAX9203.pdf">http://datasheets.maxim-ic.com/en/ds/MAX9201-MAX9203.pdf</a>
<b>National Semiconductor DS91M040 datasheet</b>	<a href="http://www.national.com/ds/DS/DS91M040.pdf">http://www.national.com/ds/DS/DS91M040.pdf</a>
<b>Official and community manuals</b>	<a href="http://www.twistedpearaudio.com/docs/docs.aspx">http://www.twistedpearaudio.com/docs/docs.aspx</a>
<b>TI Burr-Brown SRC4192</b>	<a href="http://www.ti.com/lit/ds/symlink/src4192.pdf">http://www.ti.com/lit/ds/symlink/src4192.pdf</a>
<b>TPA support forums</b>	<a href="http://www.twistedpearaudio.com/forum/default.aspx">http://www.twistedpearaudio.com/forum/default.aspx</a>