

VAUCOTTES

Loftin White + Trans-X

Cooked by P Ben

Table des matières

1	Basic concept	2
2	Modelling	3
3	The first release	4
3.1	Schematics	4
3.2	Performances	5

1 Basic concept

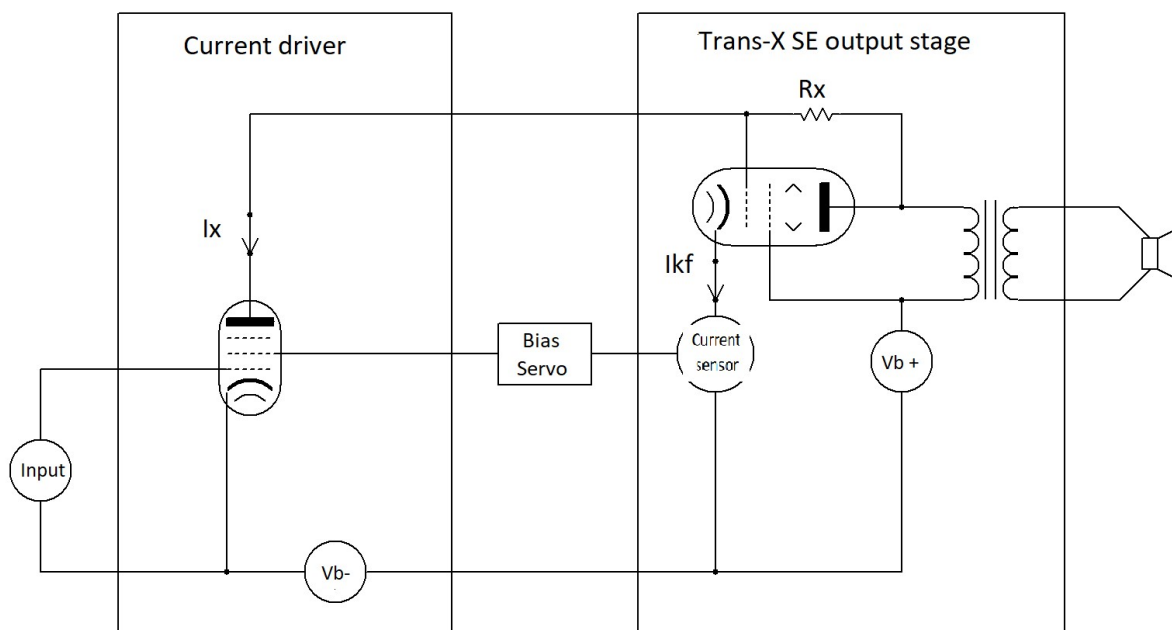

2 Modelling

Cascading a voltage dependent CCS with an I/V converter makes a Voltage amplifier

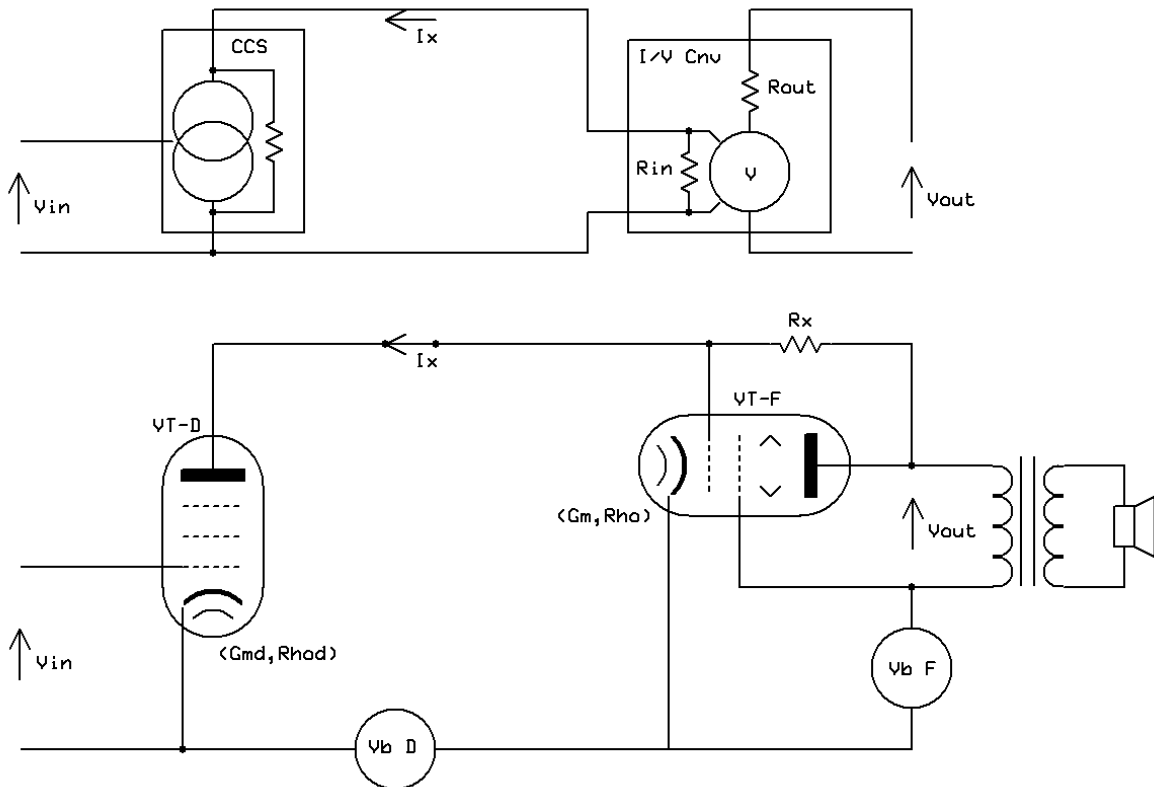

A pentode (Gm_d, ρ_d) makes an elementary CCS driven by V_{in} .

ρ_d being the driver's internal resistance (parallel), its transconductance Y_d becomes :

$$Y_d = Gm_d \times \left(1 - \frac{1}{1 + \frac{\rho_d}{R_{in}}} \right)$$

R_{in} being the internal resistor of the Trans-X output stage

When $\rho_d \gg R_{inf}$, $Y_d = Gm_d$

Using a pentode (ρ, Gm) with a convenient load (Z_l) makes a quite perfect Trans-X stage.

Assuming the values of ρ and R_x are high compared to Z_l , the basic parameters of the stage are:

$$\text{Gain (Trans-resistance) : } A_x \approx \frac{R_x}{1 + \frac{1}{Z_l \times Gm}} \approx R_x$$

$$\text{Output internal resistor : } R_{out} \approx \frac{1}{Gm \times \rho_d / (R_x + \rho_d)}$$

$$\text{Trans-X Input resistor : } R_{in} \approx \frac{R_x}{Gm \times Z_l}$$

The final gain A_v of the amp equals : $Y_d \times A_x$

Formulae being simplified, but quite accurate. You can get the complete formulae by sending me a huge participation

3 The first release

3.1 Schematics

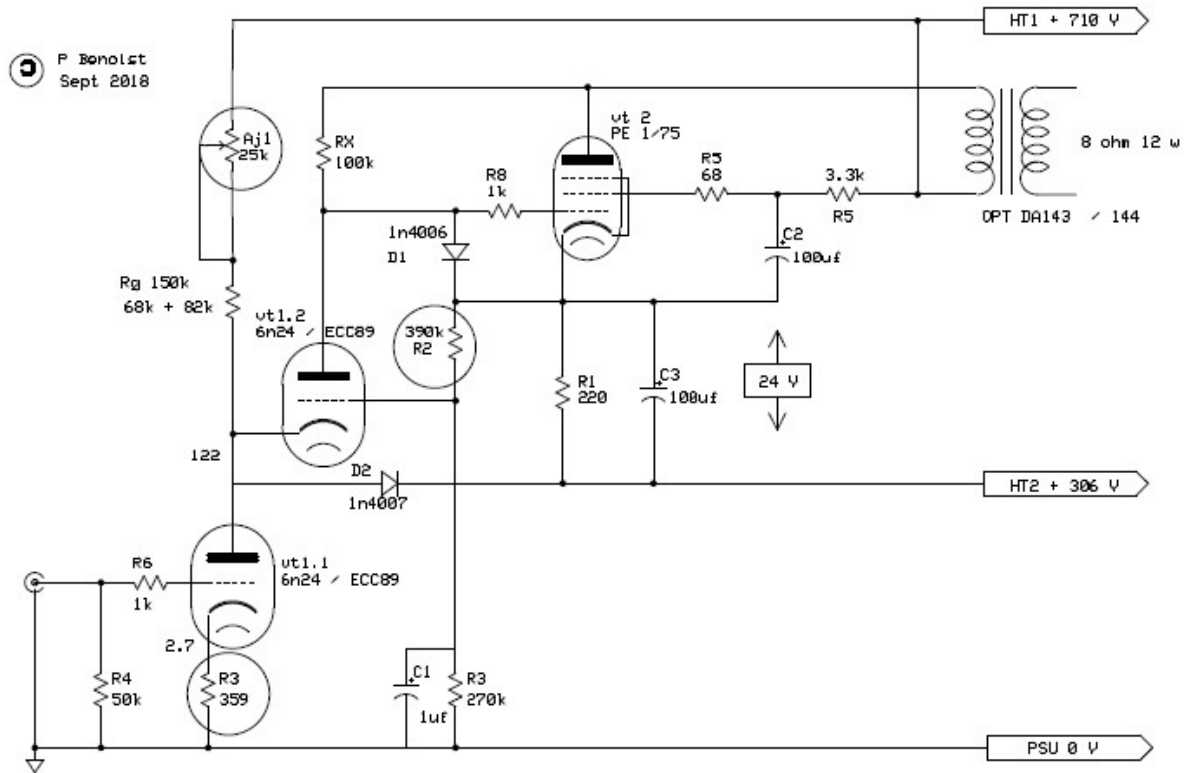

A cascode is very close to a pentode. It allows a convenient force feeding of the bottom triode and provides a much lower distortion than a single pentode, which is a major issue for the driver.

3.2 Performances

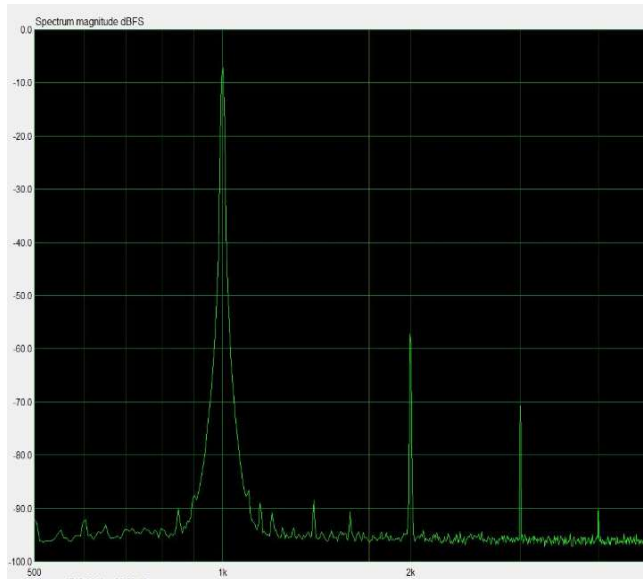

Spectrum at 1 W rms ! output. SNR > 87 dB

Max power at clipping : 13.5 W rms !

At 1 W rms ! :5.3

- DHT \approx .25%
- BW at ± 1 dB : 6 Hz to more than 30 kHz
(With DA144 OPT)

At 12 W rms ! :

- DHT < 2%
- BW (± 1 dB) : 15 Hz to more than 30 kHz
- (With DA144 OPT)

Max power at clipping : 13.5 W rms !

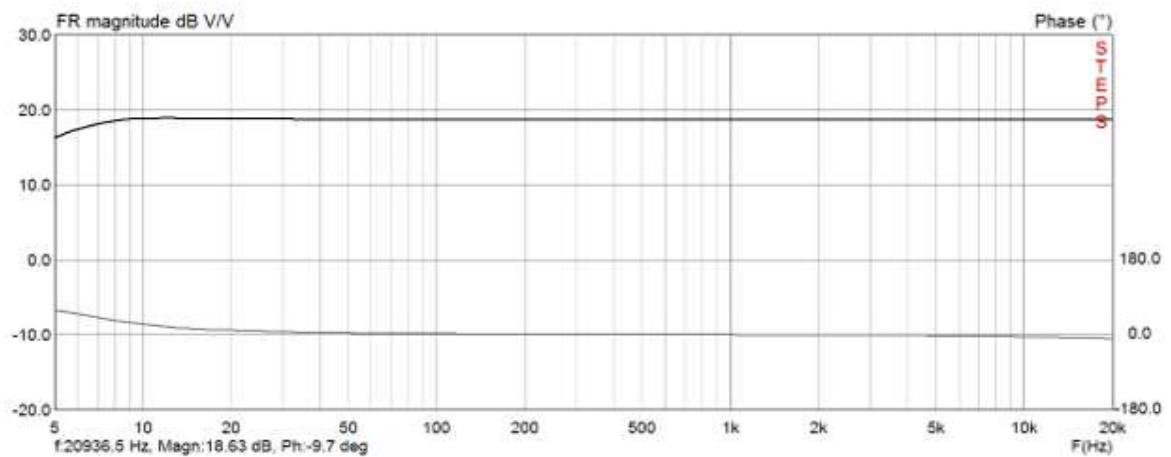

Response and phase at 1 Wrms !

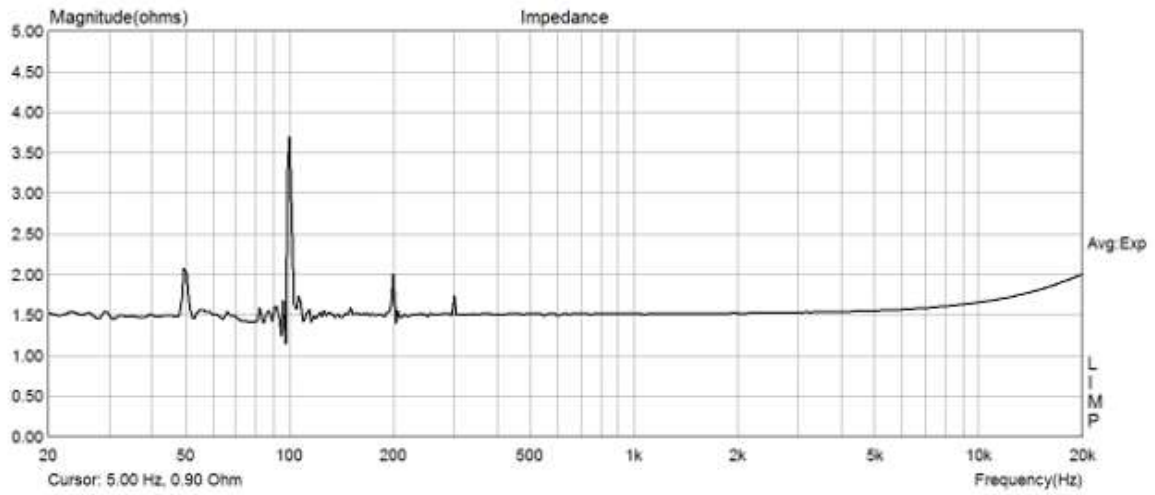

Internal resistor (with OPT DA 144) -> Damping Factor at 8 Ohm load : 5.3